

## MAGMAX

Motorreductores e Redutores de Rosca Sem-Fim

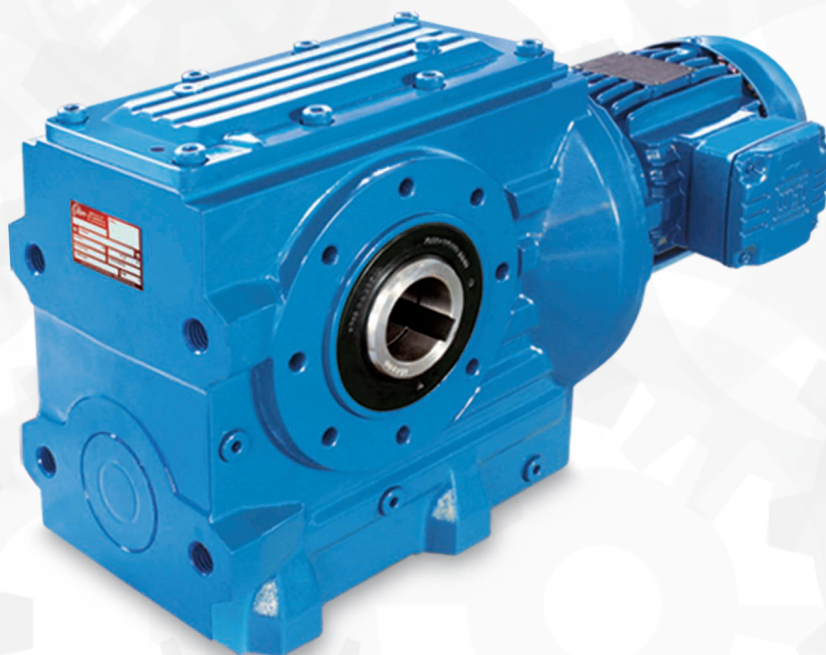



<b>Descrição</b>	<b>Página</b>	
Características gerais	2	1
Código do produto	3	2
Execução	4 - 5	3
Posição de trabalho	6	4
Posição para caixa / cabos do motor	7	5
Sentido de rotação	8	6
Seleção do motorreductor e reductor	9	7
Fator de serviço	10	8
Forças radiais admissíveis	11 - 12	9
Potência de entrada	13 - 39	10
Recálculo de potências	40	11
Características técnicas	41 - 49	12
Tabela de motores	50	13
Dimensões	51 - 80	14
Relação Motor - Redutor	81	15
Instruções de serviço	82 - 83	16
Informações técnicas	84 - 86	17
Peso dos redutores	87	18

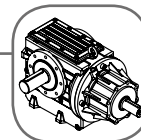

## Motorredutores

Os motorredutores MAGMAX são de estilo compacto, de construção sólida e estão disponíveis com reduções duplas, quádruplas e quádruplas; a lubrificação é por imersão em banho de óleo.

Os redutores de dupla redução são compostos de um par de engrenagens cilíndricas e um par de coroa e rosca sem fim. Os de redução quádrupla e quádrupla, chamados duplex, são formados por um redutor Coaxial acoplado em um redutor Magmax.

O motor é de construção compacta com refrigeração através de ventilador, e acoplado à carcaça do redutor por intermédio de flange e ajuste preciso, sendo o flange do motor a parede divisória entre o motor e os pares de engrenagens.

## Redutores

As carcaças são fabricadas em ferro fundido cinzento de alta qualidade, envelhecidos para que se obtenha uma usinagem precisa sem deformações posteriores.

Os redutores Magmax são constituídos de um par de engrenagens cilíndricas e um par de coroa e rosca sem fim.

As engrenagens cilíndricas são fabricadas em aço liga de alta qualidade e seus dentes são helicoidais, com ângulo de pressão a 20°, que após operação de desbaste sofrem tratamento termoquímico de cementação.

Posteriormente, os flancos dos dentes são retificados pelo processo de geração, garantindo um funcionamento silencioso. Os furos e faces das engrenagens, encostos e assentos de rolamentos e retentores são retificados garantindo um engrenamento preciso. A rosca sem fim é em aço liga para cementação que após o tratamento térmico atingirá uma dureza superficial de 58 a 60 HRc.

O perfil é de envolvente e retificado, proporcionando ao redutor um alto rendimento e um funcionamento suave. As coroas são de bronze centrifugado de liga especial, com propriedades mecânicas que garantem um ótimo funcionamento e durabilidade.

Os eixos são fabricados em aço beneficiado usado na construção de máquinas com os encostos e assentos dos rolamentos / retentores retificados.

Os rolamentos utilizados nas unidades são de precisão e resistentes a cargas radiais e axiais dimensionados para uma longa vida.

## Motores Elétricos

Os motores elétricos são trifásicos, assíncronos de indução com rotor de gaiola de esquilo, totalmente fechado com ventilação externa (TFVE).

As carcaças são conforme norma ABNT-NBR 5432, são fornecidas com grau de proteção IP55 (protegidos contra a penetração de poeira e contra projeções d'água de qualquer direção), nas tensões de 220/380 V e frequência de 60 Hz.

Os motores elétricos podem ser fornecidos com diversas modificações envolvendo: tensão, polaridade, frequência, classe de isolamento, grau de proteção, etc.

## Motofreio

O motofreio consiste de um motor e indução assíncrono trifásico, acoplado a um freio monodisco, formando uma unidade integral compacta e robusta.

O freio possui poucas partes móveis assegurando longa duração com o mínimo de manutenção. A dupla face de encosto com o disco de frenagem forma uma grande superfície de atrito, que proporciona uma pressão específica adequada sobre os elementos de fricção evitando o aquecimento exagerado, mantendo assim o mínimo de desgaste. Além disso, o freio é resfriado pela própria ventilação do motor.

A bobina de acionamento do eletroímã é protegida com resina epóxi e funciona com tensões contínuas obtidas através de uma ponte retificadora, alimentada com tensão alternada de 220, 380 ou 440 V, obtida dos terminais do motor ou de uma fonte independente.

A ponte retificadora é composta por 4 diodos retificadores de silício e 2 varistores que imprimem picos indesejáveis de tensão permitindo um rápido desligamento da corrente.

As pontes podem ser fornecidas em 220, 380 ou 440 V; quando não especificadas são fornecidas em 220 V.

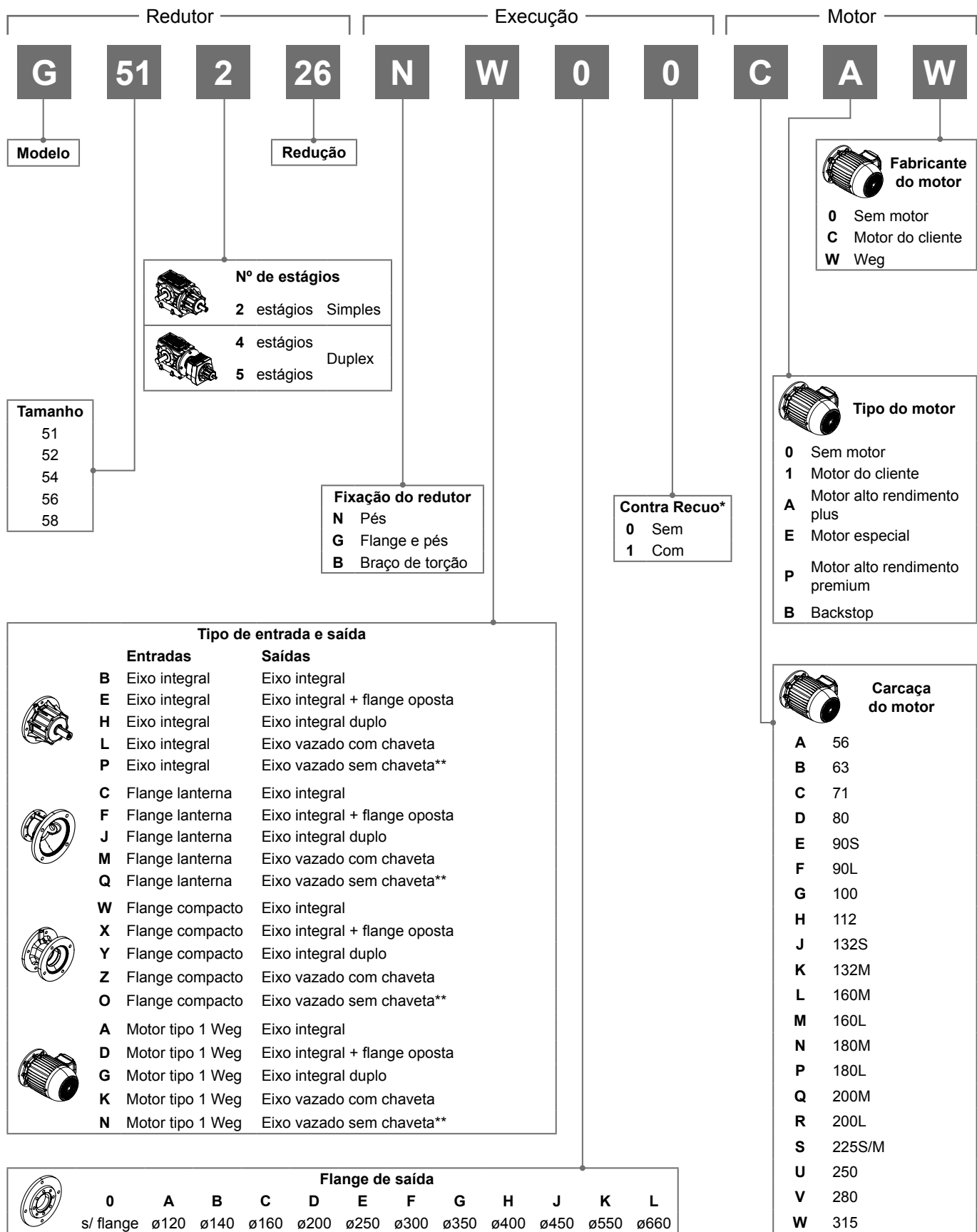

2

\* Para motor Weg Tipo 1 o contra recuo será instalado na traseira do motor elétrico, somente para carcaças 90 até 250.

\*\*Vazado sem Chaveta. Opções: disco de contração ou Easy Lock



Fixação por Pés

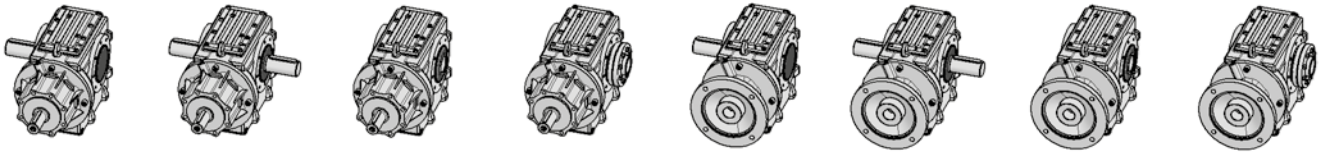

NB00 NH00 NL00 NP00 NW00 NY00 NZ00 NO00

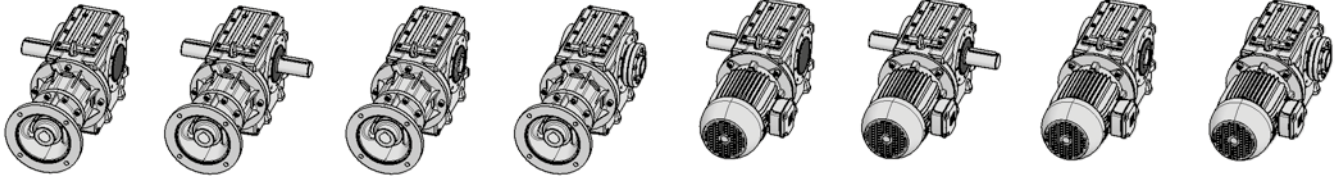

NC00 NJ00 NM00 NQ00 NA00 NG00 NK00 NN00

Fixação por Flange e Pés

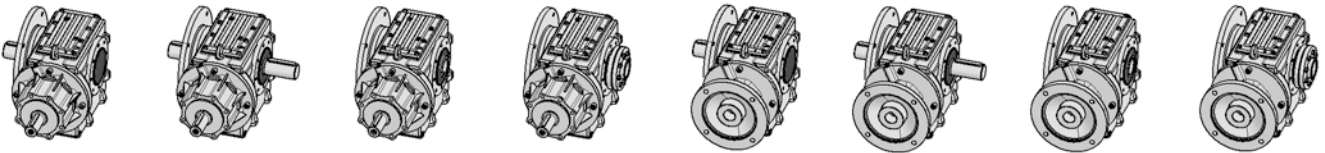

GB\_0 GH\_0 GL\_0 GP\_0 GW\_0 GY\_0 GZ\_0 GO\_0

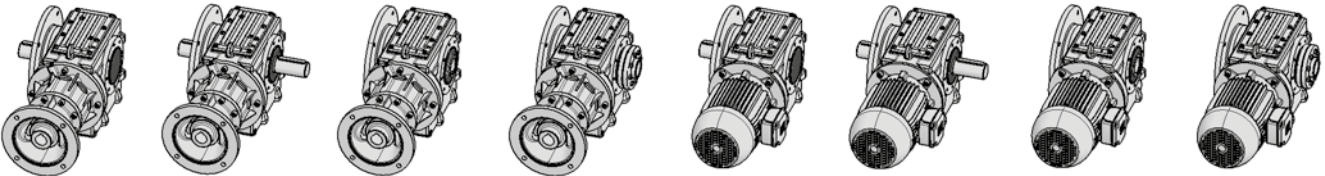

GC\_0 GJ\_0 GM\_0 GQ\_0 GA\_0 GG\_0 GK\_0 GN\_0

Fixação por Flange Oposta

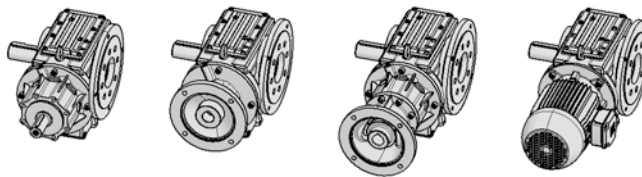

GE\_0 GX\_0 GF\_0 GD\_0

Fixação por Braço de Torção

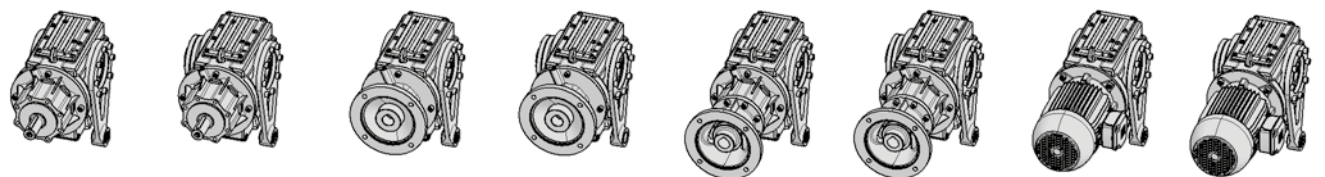

BL00 BP00 BZ00 BO00 BM00 BQ00 BK00 BN00



Fixação por Pés

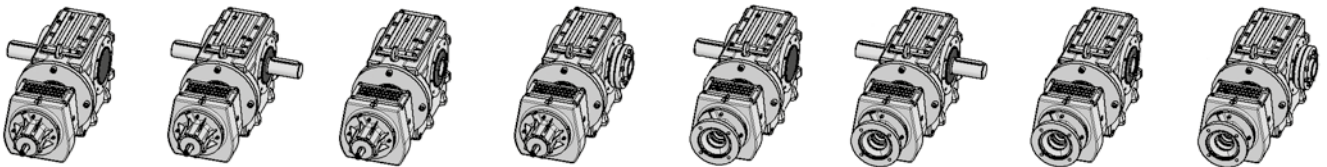

NB00 NH00 NL00 NP00 NW00 NY00 NZ00 NO00

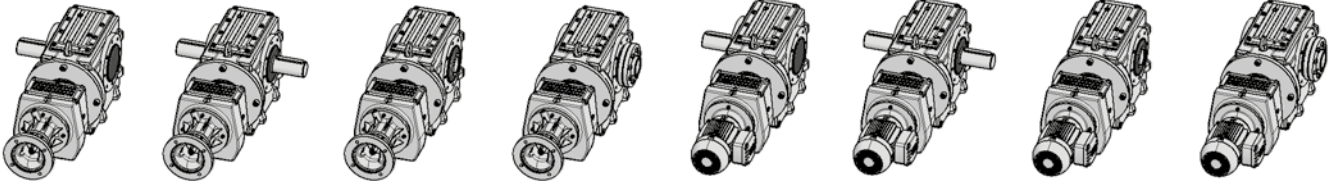

NC00 NJ00 NM00 NQ00 NA00 NG00 NK00 NN00

3

Fixação por Flange e Pés

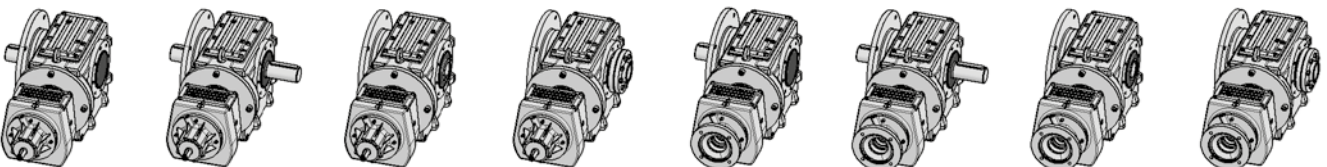

GB\_0 GH\_0 GL\_0 GP\_0 GW\_0 GY\_0 GZ\_0 GO\_0

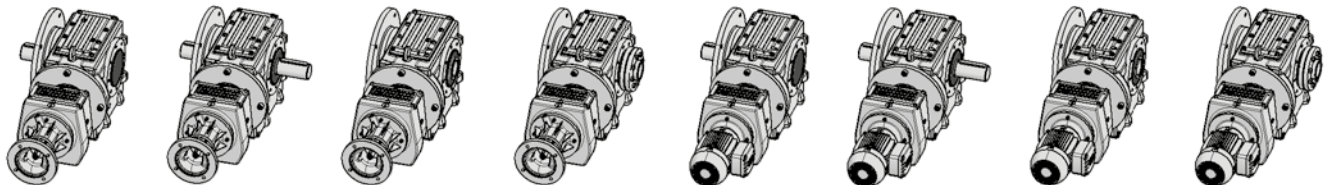

GC\_0 GJ\_0 GM\_0 GQ\_0 GA\_0 GG\_0 GK\_0 GN\_0

Fixação por Flange Oposta

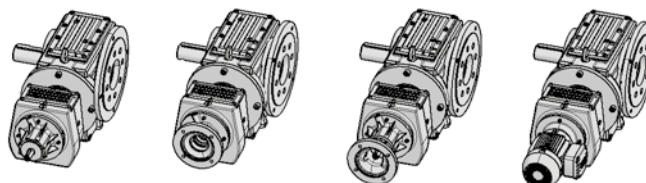

GE\_0 GX\_0 GF\_0 GD\_0

Fixação por Braço de Torção

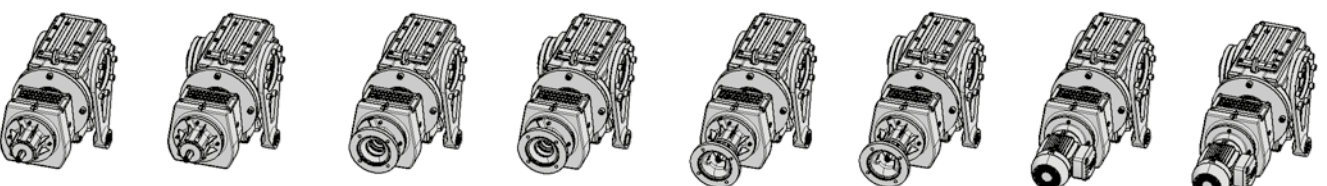

BL00 BP00 BZ00 BO00 BM00 BQ00 BK00 BN00



4

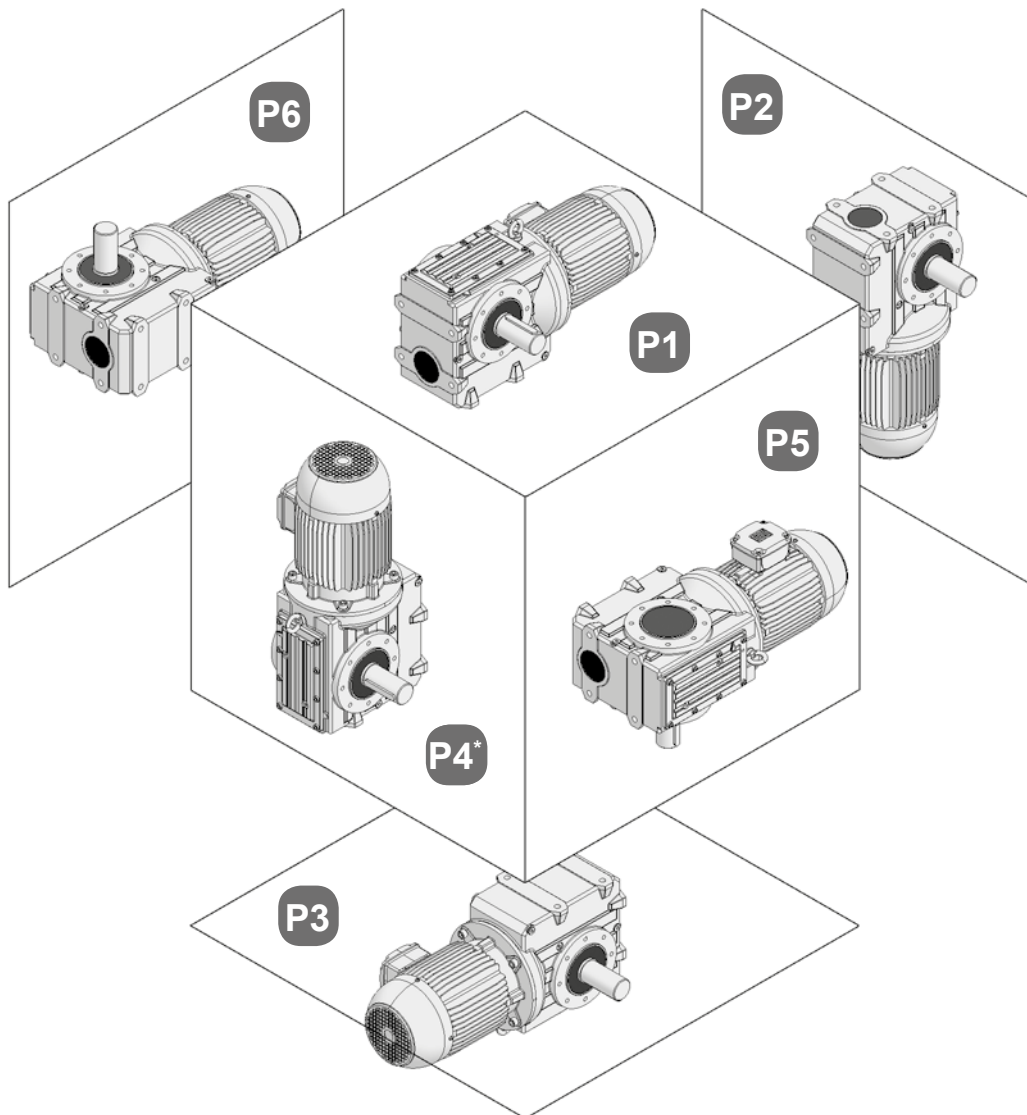

\* Para motorreductores na posição de trabalho P4 (motores com forma construtiva V1 ou V18), recomendamos a utilização de motor elétrico com proteção defletora (calota), principalmente quando expostos ao tempo.



## Posição para caixa / cabos do motor

### Posição da caixa de ligação

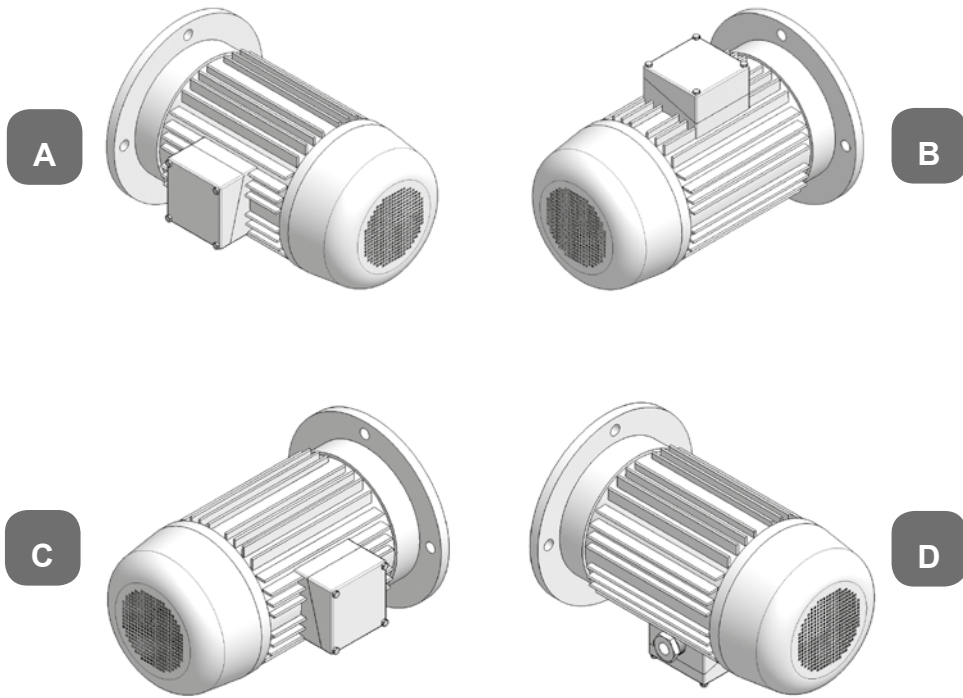

5

A caixa de ligação poderá ser montada conforme posições **A**, **B**, **C** e **D** olhando pela traseira do motor. Para a posição da caixa de ligação é considerado como referência a posição de trabalho P1 do redutor.

### Posição da entrada dos cabos do motor

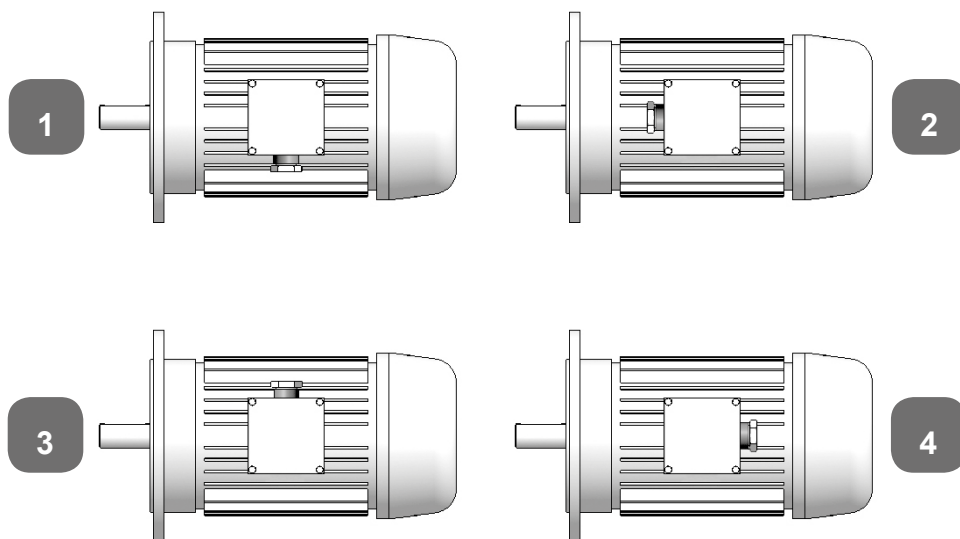

Os cabos de conexões serão disponíveis nas posições **1**, **2**, **3** e **4**, olhando de frente para a caixa de ligação. Posição caixa / cabos de ligação preferencial: A1 (itens mantidos em estoque).





2 estágios

Lado 1

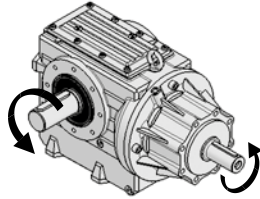

Lado 2

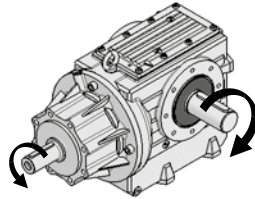
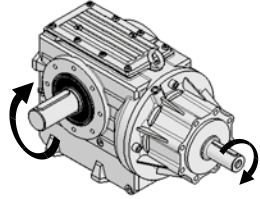
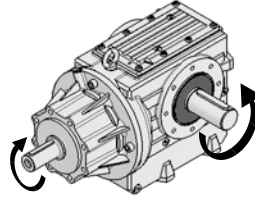

6

4 estágios

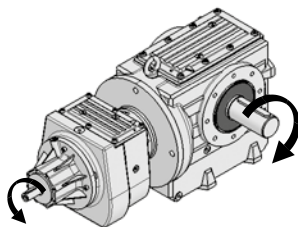
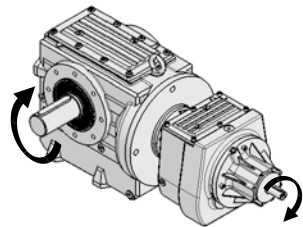
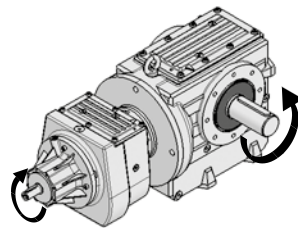
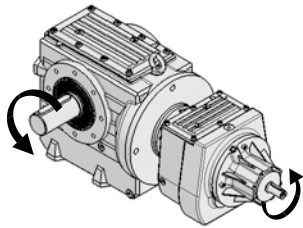

5 estágios

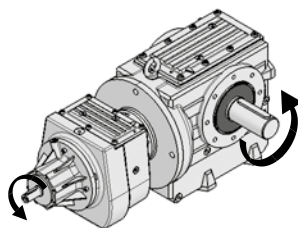
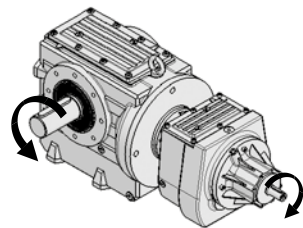
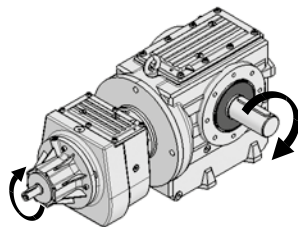
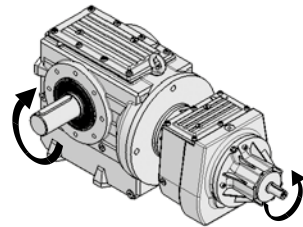



A seleção do tipo e a determinação do tamanho do motorreductor ou reductor mais adequado poderá ser feita com segurança, se levadas em consideração todas as influências às quais o motorreductor ou reductor ficará exposto durante seu funcionamento.

A observância das informações que se seguem fará com que se evitem erros e consultas repetidas na escolha, além de assegurar uma alta segurança operacional e uma longa vida útil do acionamento selecionado.

Os motorredutores e redutores **MAGMAX** são calculados para um fator de serviço igual a 1 (FS=1), isto é, um funcionamento livre de choques e um tempo de funcionamento diário de 10 horas. Para outras condições de trabalho necessitamos do fator de serviço "fa" de acordo com o indicado na tabela 1 da página 10. Estes fatores de serviço são para um acionamento com até 6 partidas/hora. Para partidas superiores a 6, consultar a CESTARI.

Os valores de rotação de saída n2 dos motorredutores indicados nas tabelas de potências são aproximados, estes dependem do tamanho do motor e da carga relativa que incide sobre o mesmo, bem como a rede elétrica. Variações de até ±4% são admissíveis.

### 1) Determinação do tamanho do motorreductor ou reductor

#### 1) Escolha do motorreductor

Conhecendo-se a potência necessária de acionamento "Pa" [kW] e a rotação de saída do motorreductor "n2" [rpm], e com o fator de serviço "fa" obtido na tabela 1 da pág. 10, podemos escolher o motorreductor diretamente nas tabelas de potências das págs. 13 até 39, cuidando-se para que:

**Fator de serviço do reductor = fs ≥ fa**

#### 2) Escolha do reductor

Com a potência necessária de acionamento "Pa2" [kW] e a rotação de saída do reductor "n2" [rpm], e conforme a tabela 1 da pág. 10, com o fator de serviço "fa" determinamos o momento torçor equivalente de acionamento "Me" [Nm]:

$$Ma = 9550 \cdot \frac{Pa2}{n2} \text{ (Nm)}$$

Pa2 = Pa1 (potência de entrada) x rendimento

Para rendimento, procurar nas páginas de Características Técnicas.

Para a seleção do reductor devemos encontrar nas tabelas de potências das págs. 13 até 39 um tamanho de reductor que obtenha a condição:

**Mmax ≥ Me**

Mmax = Momento Torçor Máximo admissível ao reductor

#### Exemplos:

Motorreductor: G52224 NA00 CNW P1 A1 (pág. 22)

Tamanho do reductor	52
Rotação de saída	108 rpm
Fator de serviço	4,96
Código do motor	CNW (pág. 50)
Potência do motor	0,55 kW
Execução NA00	(Dimensões pág. 54)
Posição de trabalho	P1 (pág. 6)
Posição da caixa de ligação e entrada dos cabos do motor	A1 (pág. 7)

Redutor: G58232 NB00 000 P1 (pág. 48)

Tamanho do reductor 58

Rotação de saída	45,6 rpm
Redução total	38,3
Momento Torçor máximo	1550 Nm
Execução	NB00 (Dimens. pág. 63)
Posição de Trabalho	P1 (pág. 6)

### 2) Exemplo de cálculo e seleção:

Selecionar um motorreductor para acionamento de um transportador de correias.

#### Dados conhecidos:

Potência de acionamento	Pa = 9,2 kW
Rotação de saída desejado	n2 = 60 rpm
Período de funcionamento	t = 24 h/dia

#### Solução:

Na tabela 1, página 10, obtemos o fator de serviço:

Equipamento acionado	Transportador de correia
Classe de Carga	Uniforme
Tempo de funcionamento	acima de 10 h/dia

≥ Fator de Serviço "fa" = 1,25

Conforme a tabela de potência Pa = 9,2 kW da pág.37, selecionamos para a condição fs ≥ fa o motorreductor G58229 \_\_\_KNW que nos fornece :

Tamanho do reductor	58
Rotação de saída	n2=65,0 rpm
Potência do motor	Pa=9,2 kW
Fator de serviço do reductor	fs=1,60 ≥ fa
Código do motor (pág. 46)	KNW

Para uma seleção completa do motorreductor deve-se determinar a execução, posição de trabalho, posição da caixa e de entrada dos cabos do motor.

### 3) Informações para seleção dos motorredutores e redutores

- a. Tipo de máquina a ser acionada  
Potência nominal em kW, rotação em rpm  
Redução total desejada
- b. Momento de Inércia "J" a serem acionados  
Tipo de funcionamento (uniforme, com choques moderados ou fortes)
- c. Tempo de funcionamento diário em horas
- d. Condições ambientais  
Temperatura ambiente, umidade, gases corrosivos, ambientes sujos, etc.
- e. Força radial e axial externas (págs. 11 e 12)
- f. Partidas por hora
- g. Posição de trabalho (pág. 6)
- h. Execução
- i. Voltagem e frequência
- j. Posição da caixa de ligação e de entrada dos cabos do motor (pág. 7)
- k. Tipos e dimensões dos elementos montados no eixo do reductor  
Polia, engrenagens, pinhões de corrente, etc.

**Tabela 1**

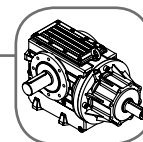

**U** Cargas uniformes  
**M** Choques moderados  
**F** Choques fortes

Aplicação	Classe de carga	Aplicação	Classe de carga	Aplicação	Classe de carga
<b>Agitadores</b>		<b>Draças</b>		<b>Máquinas operatrizes</b>	
Líquidos puros	U	Guinchos, transportadores e bombas	M	Acionamento principal - Cargas pesadas	F
Líquidos de densidade consistente	M	Cabeçotes rotativos e peneiras	F	Acionamento principal - Cargas uniformes	M
Líquidos de densidade variável	M	Esteira de translação	F	Acionamento auxiliar	U
<b>Alimentadores</b>		<b>Elevadores</b>		Rosqueadoras	F
Alimentadores de rosca	M	Caçambas - cargas uniformes	U	<b>Misturadores</b>	
Transportadores (esteira e correia)	M	Caçambas - cargas pesadas	F	Betoneiras	M
<b>Ascensores</b>		Elevadores de carga	M	Borracha	F
Sorilhos de elevação	F	Elevadores de canecas carregadas normalmente	U	Polpa de papel	M
Máquinas de extração	F	Elevadores de canecas muito carregadas	M	Fluidos com substâncias sólidas	M
Monta - cargas solicitadas normalmente	M	Elevadores para pessoas**	**	Fluidos limpos	U
Monta - cargas solicitadas fortemente	F	<b>Engarrafadoras e Enlatadoras</b>		<b>Moinhos Rotativos</b>	
Monta - cargas inclinadas	F			De bolas e rolos	F
<b>Bobinadoras</b>		<b>Fornos Rotativos</b>		De martelos	F
Metal	M			<b>Papel</b>	
Papel	M	<b>Geradores</b>		Agitadores misturadores, alvejadores, batedores, despaldadores, calandras e prensas	M
Têxtil	U	Alternadores	U	Supercalandras*	*
<b>Bombas</b>		Conversores de frequência	F	Descascadores hidráulicos e mecânicos	M
Centrífugas - liq. de baixa viscosidade	U	<b>Guinchos e Guindastes</b>		Tambores descascadores	F
Centrífugas - liq. de alta viscosidade	M	Elevação moderada	M	Esticadores de feltro	M
Dupla ação, multicilíndricas	M	Elevação pesada	F	Secadores	F
Recíprocos de descarga livre	M	Giro	M	<b>Peneiras</b>	
Rotativas a engrenagens	U	Translação	F	Peneiras horizontais	M
Pistão submerso	F	<b>Indústrias Açucareiras</b>		Peneiras para filtragem do ar	U
Pressão	F	Moendas*	*	Peneiras rotativas para pedras e areia	M
<b>Borracha e Plástico</b>		Facas de cana*	*	<b>Pontes rolantes</b>	
Calandras*	*	Cristalizadores	F	Acionamento do carro e da ponte	F
Equipamentos de laboratório	M	<b>Indústrias Alimentícias</b>		Acionamento do guincho	U
Extrusoras*	*	Cozinheiros de cereais	M	<b>Saneamento</b>	
Laminadores	F	Misturadores de massa, moedores de carne, picadores	M	Aeradores	F
Máquinas de placas	M	Centrífugas ligeiras	M	Alimentadores, bombas, decantadores	U
Máquinas de tubo e peneiras	M	Centrífugas pesadas	F	Filtros mexedores e peneiras	M
Moinhos cilíndricos 2 em linha*	*	<b>Indústrias Madeireiras</b>		Clarificadores	U
Moinhos cilíndricos 3 em linha*	*	Alimentadores de plaina	M	<b>Secadores e resfriadores rotativos</b>	
Refinadores*	*	Serras, tambores despaldadores, transportadores de toras	F	Produtos alimentícios, Bagaça	M
Trituradores e misturadores*	*	Máquinas p/ trabalhar madeira em geral	M	<b>Torres de refrigeração**</b>	
<b>Britadores</b>		<b>Indústrias Metalúrgicas</b>			
Pedras e minerais	F	Cortadores de chapa rotativas	M	<b>Transportadores</b>	
<b>Cerâmica</b>		Cortadores de chapa de faca	F	Caçamba, correia, corrente, esteira, rosca:	
Amassadores de barro	M	Viradeiras	F	- Cargas uniformes	U
Extrusoras e misturadores	M	Trefilas	M	- Cargas pesadas e intermitentes	M
Moinhos de barro*	*	Desempenadeiras a rolos	F	<b>Transmissões</b>	
Prensas de tijolos e ladrilhos	F	Enroladores de fitas ou bobinadoras de chapas	F	Transmissões ligeiras	U
<b>Cimento</b>		Laminadores	F	Transmissões para acionamentos de máquinas ferramentas	M
Britadores de mandíbulas	F	Máquinas de soldar tubos	F	<b>Ventiladores</b>	
Moinhos rotativos*	*	<b>Indústrias de óleo</b>		Centrífugas	U
Moinhos de bolas e rolos*	*	Prensas - filtros de parafina	M	Para minas	F
<b>Classificadores Rotativos</b>		Bombas de pipe-line	M	Para torres de refrigeração	M
		Máquinas de refinação	M	<b>Tempo máximo de funcionamento diário</b>	
<b>Compressores</b>		Instalações de perfuradores rotativos	F	Até 3 horas	0,8 1,0 1,5
Centrífugos	U	<b>Indústrias têxteis</b>		Até 10 horas	1,0 1,25 1,75
Êmbolo giratório	M	Calandras, cardas, filatórios, retorcedoras, maçoqueiras e máquinas de tinturaria	M	24 horas	1,25 1,5 2,0
Pistão (um cilindro)	F	<b>Lavanderias</b>			
Pistão (2 cilindros) coeficiente de irregularidade < 1:100	F	Secadores rotativos	M		
<b>Destilarias</b>		Máquinas de lavar roupa	M		
Cozinheiros - serviço contínuo	U	Acionamento de grelhas móveis	F		
Tachas de fermentação- serviço contínuo	U				
Misturadores	U				

\*Fator de serviço mínimo recomendado: 2,00

\*\* Para torres de refrigeração e elevadores de pessoas, deve ser analisado redutor específico.



Quando a transmissão de força for através de acoplamento elástico, não ocorrerá força radial e axial no eixo do redutor. Entretanto, se a transmissão for por intermédio de elementos montados no eixo (engrenagens, pinhões de corrente ou polias), será constatado a existência de cargas radiais e/ou axiais.

Usando as Tabelas de Potências (motorreduzores - página 13 até 39) ou Características Técnicas (reduzores - página 41 até 49) obtém-se as cargas radiais admissíveis no eixo do redutor. Forças axiais até 50% das forças radiais admissíveis podem ser absorvidas simultaneamente com as forças radiais.

Os valores das forças radiais indicado nas tabelas referem-se a carga aplicada no centro do comprimento "L" (figura abaixo). Quando a distância de aplicação "x" for diferente de "Xr" deverá haver um recálculo conforme fórmulas e tabelas abaixo; se a carga radial for aplicada a uma distância "x" menor que "Xr", e o seu valor igual ou menor que o admissível, não haverá necessidade de recálculo.

### Determinação da força radial admissível no ponto x: F(x)

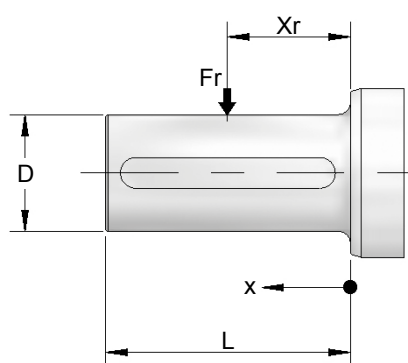

a) F1 (x) baseada no tempo de vida do rolamento:

$$F1(x) = \frac{k}{m + x} \cdot Fr \quad [N]$$

b) F2 (x) baseada em flexão máxima do eixo:

$$F2(x) = \frac{1000 \cdot n}{p + x} \quad [N]$$

**Tabela 2 Carga radial (Fr) em N - Eixo de entrada (2 estágios)**

Redução	51	52	54	56	58
>6,3 a 9	500	600	800	1200	1500
>9 a 18	800	900	1000	1600	2200
>18 a 35,5	900	1100	1200	1800	2400
>35,5 a 90	1200	1400	1500	2000	2600
>90 a 180	1400	1800	1800	2200	2800

**Tabela 3**

Valores para recálculo de cargas radiais no eixo de saída

Tamanho	k	m	n	p	D	L
51	140	115	114	18	25	40
52	150	120	225	20	30	50
54	160	125	329	22	30	50
56	180	135	480	25	40	70
58	225	175	657	28	50	90

**Tabela 4**

Valores para recálculo de cargas radiais no eixo de entrada

Tamanho	k	m	n	p	D	L
51	110	90	53,2	18	19	40
52	130	110	72	20	19	40
54	150	130	75,6	22	19	40
56	170	140	121	25	28	60
58	210	170	190,4	28	38	80

\* Força radial na entrada pode ser aumentada considerando mancal reforçado - consultar.

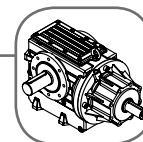

**Tabela 5 Carga radial (Fr) em N - Eixo de entrada (4 e 5 estágios)**

Estágios	51, 52	54, 56	58
4	300	400	600
5	800	900	1000

**Tabela 6**

Valores para recálculo de cargas radiais no eixo de entrada para redutores duplex

Tamanho	k	m	n	p	D	L
51, 52	110	90	53,2	18	19	40
54, 56	130	110	72	20	19	40
58	150	130	75,6	22	19	40

9

**Diâmetro mínimo admissível para o elemento de transmissão montado no eixo:**

Em conjunto com a carga radial obtida, o menor diâmetro admissível para o elemento de transmissão (engrenagens, pinhões de corrente ou polias) pode ser calculado usando a seguinte fórmula:

**Valores para o fator Kr**

Correia plana com esticador	2,5
Correia plana sem esticador	5
Correia trapezoidal sem esticador	1,75
Corrente de rolos ou corrente silenciosa	1,4
Engrenagens	1,15

$$D_{min} = \frac{2.000 \cdot M_c}{F_r} \cdot K_r$$





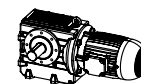

**Onde**

- Dmin = Diâmetro mínimo admissível (mm)
- Mc = Momento a ser transmitido (Nm)
- Fr = Carga radial admissível no eixo do redutor (N)
- Kr = Fator adicional



## 0,12 kW - 1750 rpm



rpm	ítot	fs	Fr (N)	código	páginas
					
235	7,44	14,14	1600	G51218	51 a 53
197	8,90	15,97	1700	G51219	51 a 53
174	10,0	15,32	1800	G51220	51 a 53
161	10,9	15,41	2000	G51221	51 a 53
147	11,9	15,51	2200	G51222	51 a 53
127	13,7	13,47	2400	G51223	51 a 53
112	15,6	11,83	2500	G51224	51 a 53
99,3	17,6	10,49	2800	G51225	51 a 53
85,7	20,4	9,05	2900	G51226	51 a 53
81,3	21,5	9,88	3000	G51227	51 a 53
72,1	24,3	8,74	3000	G51228	51 a 53
60,8	28,8	7,37	3000	G51229	51 a 53
52,6	33,3	6,38	3000	G51230	51 a 53
46,2	37,9	5,60	3000	G51232	51 a 53
41,0	42,6	4,98	3000	G51233	51 a 53
35,4	49,4	4,30	3000	G51234	51 a 53
32,7	53,4	3,98	3000	G51235	51 a 53
29,7	59,0	3,60	3000	G51236	51 a 53
22,8	76,8	3,42	3000	G51238	51 a 53
19,7	88,7	2,96	3000	G51239	51 a 53
17,3	101	2,60	3000	G51240	51 a 53
15,4	114	2,30	3000	G51241	51 a 53
13,3	132	1,99	3000	G51242	51 a 53
12,3	143	1,84	3000	G51243	51 a 53
11,1	157	1,67	3000	G51244	51 a 53
9,87	177	1,48	3000	G51245	51 a 53
8,67	202	1,30	3000	G51246	51 a 53
7,70	227	1,85	3000	G51247	51 a 53
6,64	264	1,59	3000	G51248	51 a 53
5,56	315	1,33	3000	G51250	51 a 53
19,4	90,0	5,25	5000	G52239	54 a 56
17,9	97,6	4,85	5000	G52240	54 a 56
15,7	111	4,26	5000	G52241	54 a 56
13,9	126	3,75	5000	G52242	54 a 56
12,4	141	3,35	5000	G52243	54 a 56
10,8	162	2,92	5000	G52244	54 a 56
10,00	175	2,70	5000	G52245	54 a 56
9,11	192	2,46	5000	G52246	54 a 56



0,12 kW - 1750 rpm

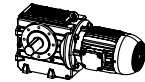

rpm	ítot	fs	Fr (N)	código	páginas
7,86	223	3,38	5000	G52247	54 a 56
6,96	251	3,00	5000	G52248	54 a 56
5,39	325	2,32	5000	G52250	54 a 56
5,00	350	2,15	5000	G52251	54 a 56
4,56	384	1,96	5000	G52252	54 a 56
9,35	187	4,22	7000	G54245	57 a 59
7,86	223	5,64	7000	G54247	57 a 59
6,96	251	5,01	7000	G54248	57 a 59
5,39	325	3,87	7000	G54250	57 a 59
5,00	350	3,59	7000	G54251	57 a 59
4,56	384	3,27	7000	G54252	57 a 59
4,03	434	5,79	8000	G56252	60 a 62
3,53	495	5,08	8000	G56253	60 a 62
3,26	537	6,46	8000	G56254	60 a 62
4,02	436	0,91	5000	G52453	69 a 71
3,04	576	0,86	5000	G52456	69 a 71
3,85	454	1,46	7000	G54453	72 a 74
3,36	521	1,27	7000	G54454	72 a 74
3,15	556	1,48	7000	G54455	72 a 74
2,76	634	1,30	7000	G54456	72 a 74
2,41	728	1,13	7000	G54457	72 a 74
2,24	781	1,05	7000	G54458	72 a 74
2,14	817	1,01	7000	G54459	72 a 74
1,75	1,002	0,82	7000	G54460	72 a 74
3,21	545	3,01	8000	G56455	75 a 77
2,99	586	2,80	8000	G56456	75 a 77
2,43	719	2,28	8000	G56457	75 a 77
2,13	820	2,00	8000	G56458	75 a 77
1,86	941	1,75	8000	G56459	75 a 77
1,73	1,011	1,62	8000	G56460	75 a 77
1,66	1,057	1,55	8000	G56461	75 a 77
1,35	1,296	1,27	8000	G56462	75 a 77
1,18	1,479	1,11	8000	G56463	75 a 77
1,03	1,697	0,97	8000	G56464	75 a 77

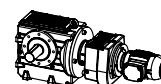
**0,12 kW - 1750 rpm**

rpm	Ítot	fs	Fr (N)	código	páginas
0,960	1,823	0,90	8000	G56465	75 a 77
0,885	1,976	0,83	8000	G56466	75 a 77
3,15	555	6,41	9000	G58455	78 a 80
2,83	618	5,76	9000	G58456	78 a 80
2,54	689	5,16	9000	G58457	78 a 80
2,35	745	2,00	9000	G58458	78 a 80
1,94	901	3,95	9000	G58459	78 a 80
1,69	1,034	3,44	9000	G58460	78 a 80
1,52	1,154	3,08	9000	G58461	78 a 80
1,40	1,248	2,85	9000	G58462	78 a 80
1,29	1,355	2,63	9000	G58463	78 a 80
1,16	1,508	2,36	9000	G58464	78 a 80
1,00	1,744	2,04	9000	G58465	78 a 80
0,848	2,063	1,72	9000	G58466	78 a 80
0,756	2,314	1,54	9000	G58467	78 a 80
0,638	2,743	1,30	9000	G58468	78 a 80
0,594	2,947	1,21	9000	G58469	78 a 80
0,529	3,311	1,07	9000	G58470	78 a 80
0,536	3,267	1,11	9000	G58571	78 a 80
0,437	4,007	0,91	9000	G58572	78 a 80

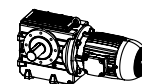
**0,18 kW - 1750 rpm**

235	7,44	9,43	1600	G51218	51 a 53
197	8,90	10,65	1700	G51219	51 a 53
174	10,0	10,21	1800	G51220	51 a 53
161	10,9	10,27	2000	G51221	51 a 53
147	11,9	10,34	2200	G51222	51 a 53
127	13,7	8,98	2400	G51223	51 a 53
112	15,6	7,89	2500	G51224	51 a 53
99,3	17,6	6,99	2800	G51225	51 a 53
85,7	20,4	6,03	2900	G51226	51 a 53
81,3	21,5	6,58	3000	G51227	51 a 53
72,1	24,3	5,83	3000	G51228	51 a 53
60,8	28,8	4,92	3000	G51229	51 a 53
52,6	33,3	4,25	3000	G51230	51 a 53
46,2	37,9	3,74	3000	G51232	51 a 53
41,0	42,6	3,32	3000	G51233	51 a 53



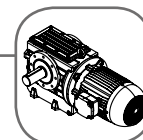

0,18 kW - 1750 rpm

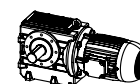

rpm	ítot	fs	Fr (N)	código	páginas
35,4	49,4	2,87	3000	G51234	51 a 53
32,7	53,4	2,65	3000	G51235	51 a 53
29,7	59,0	2,40	3000	G51236	51 a 53
22,8	76,8	2,28	3000	G51238	51 a 53
19,7	88,7	1,97	3000	G51239	51 a 53
17,3	101	1,73	3000	G51240	51 a 53
15,4	114	1,54	3000	G51241	51 a 53
13,3	132	1,33	3000	G51242	51 a 53
12,3	143	1,22	3000	G51243	51 a 53
11,1	157	1,12	3000	G51244	51 a 53
9,87	177	0,99	3000	G51245	51 a 53
8,67	202	0,87	3000	G51246	51 a 53
7,70	227	1,23	3000	G51247	51 a 53
6,64	264	1,06	3000	G51248	51 a 53
5,56	315	0,89	3000	G51250	51 a 53
37,1	47,1	5,41	4500	G52233	54 a 56
33,1	52,9	4,82	5000	G52235	54 a 56
28,7	60,9	4,18	5000	G52236	54 a 56
24,3	72,0	3,54	5000	G52237	54 a 56
20,9	83,8	3,76	5000	G52238	54 a 56
19,4	90,0	3,50	5000	G52239	54 a 56
17,9	97,6	3,23	5000	G52240	54 a 56
15,7	111	2,84	5000	G52241	54 a 56
13,9	126	2,50	5000	G52242	54 a 56
12,4	141	2,24	5000	G52243	54 a 56
10,8	162	1,95	5000	G52244	54 a 56
10,00	175	1,80	5000	G52245	54 a 56
9,11	192	1,64	5000	G52246	54 a 56
7,86	223	2,25	5000	G52247	54 a 56
6,96	251	2,00	5000	G52248	54 a 56
5,39	325	1,55	5000	G52250	54 a 56
5,00	350	1,44	5000	G52251	54 a 56
4,56	384	1,31	5000	G52252	54 a 56
14,3	123	4,27	7000	G54242	57 a 59
12,7	138	3,81	7000	G54243	57 a 59
11,1	158	3,33	7000	G54244	57 a 59
9,35	187	2,81	7000	G54245	57 a 59



0,18 kW - 1750 rpm

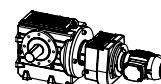

rpm	Ítot	fs	Fr (N)	código	páginas
7,86	223	3,76	7000	G54247	57 a 59
6,96	251	3,34	7000	G54248	57 a 59
5,39	325	2,58	7000	G54250	57 a 59
5,00	350	2,39	7000	G54251	57 a 59
4,56	384	2,18	7000	G54252	57 a 59
4,03	434	3,86	8000	G56252	60 a 62
3,53	495	3,39	8000	G56253	60 a 62
3,26	537	3,12	8000	G56254	60 a 62
3,85	454	0,97	7000	G54453	72 a 74
3,36	521	0,85	7000	G54454	72 a 74
3,15	556	0,98	7000	G54455	72 a 74
2,76	634	0,86	7000	G54456	72 a 74
3,21	545	2,01	8000	G56455	75 a 77
2,99	586	1,87	8000	G56456	75 a 77
2,43	719	1,52	8000	G56457	75 a 77
2,13	820	1,34	8000	G56458	75 a 77
1,86	941	1,16	8000	G56459	75 a 77
1,73	1,011	1,08	8000	G56460	75 a 77
1,66	1,057	1,04	8000	G56461	75 a 77
1,35	1,296	0,84	8000	G56462	75 a 77
3,15	555	4,27	9000	G58455	78 a 80
2,83	618	3,84	9000	G58456	78 a 80
2,54	689	3,44	9000	G58457	78 a 80
2,35	745	3,18	9000	G58458	78 a 80
1,94	901	2,63	9000	G58459	78 a 80
1,69	1,034	2,29	9000	G58460	78 a 80
1,52	1,154	2,06	9000	G58461	78 a 80
1,40	1,248	1,90	9000	G58462	78 a 80
1,29	1,355	1,75	9000	G58463	78 a 80
1,16	1,508	1,57	9000	G58464	78 a 80
1,00	1,744	1,36	9000	G58465	78 a 80
0,848	2,063	1,15	9000	G58466	78 a 80
0,756	2,314	1,03	9000	G58467	78 a 80
0,638	2,743	0,86	9000	G58468	78 a 80
0,594	2,947	0,80	9000	G58469	78 a 80



0,25 kW - 1750 rpm

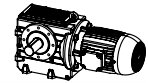





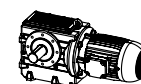

rpm	ítot	fs	Fr (N)	código	páginas
235	7,44	6,79	1600	G51218	51 a 53
197	8,90	7,66	1700	G51219	51 a 53
174	10,0	7,35	1800	G51220	51 a 53
161	10,9	7,40	2000	G51221	51 a 53
147	11,9	7,44	2200	G51222	51 a 53
127	13,7	6,47	2400	G51223	51 a 53
112	15,6	5,68	2500	G51224	51 a 53
99,3	17,6	5,03	2800	G51225	51 a 53
85,7	20,4	4,34	2900	G51226	51 a 53
81,3	21,5	4,74	3000	G51227	51 a 53
72,1	24,3	4,19	3000	G51228	51 a 53
60,8	28,8	3,54	3000	G51229	51 a 53
52,6	33,3	3,06	3000	G51230	51 a 53
46,2	37,9	2,69	3000	G51232	51 a 53
41,0	42,6	2,39	3000	G51233	51 a 53
35,4	49,4	2,06	3000	G51234	51 a 53
32,7	53,4	1,91	3000	G51235	51 a 53
29,7	59,0	1,73	3000	G51236	51 a 53
22,8	76,8	1,64	3000	G51238	51 a 53
19,7	88,7	1,42	3000	G51239	51 a 53
17,3	101	1,25	3000	G51240	51 a 53
15,4	114	1,11	3000	G51241	51 a 53
13,3	132	0,96	3000	G51242	51 a 53
12,3	143	0,88	3000	G51243	51 a 53
11,1	157	0,80	3000	G51244	51 a 53
7,70	227	0,89	3000	G51247	51 a 53
47,8	36,6	5,01	4100	G52231	54 a 56
41,9	41,7	4,40	4300	G52232	54 a 56
37,1	47,1	3,90	4500	G52233	54 a 56
33,1	52,9	3,47	5000	G52235	54 a 56
28,7	60,9	3,01	5000	G52236	54 a 56
24,3	72,0	2,55	5000	G52237	54 a 56
20,9	83,8	2,71	5000	G52238	54 a 56
19,4	90,0	2,52	5000	G52239	54 a 56
17,9	97,6	2,33	5000	G52240	54 a 56
15,7	111	2,05	5000	G52241	54 a 56
13,9	126	1,80	5000	G52242	54 a 56



## 0,25 kW - 1750 rpm



rpm	Ítot	fs	Fr (N)	código	páginas
					
12,4	141	1,61	5000	G52243	54 a 56
10,8	162	1,40	5000	G52244	54 a 56
10,00	175	1,30	5000	G52245	54 a 56
9,11	192	1,18	5000	G52246	54 a 56
7,86	223	1,62	5000	G52247	54 a 56
6,96	251	1,44	5000	G52248	54 a 56
5,39	325	1,11	5000	G52250	54 a 56
5,00	350	1,03	5000	G52251	54 a 56
4,56	384	0,94	5000	G52252	54 a 56
23,5	74,4	4,11	7000	G54237	57 a 59
21,4	81,7	4,63	7000	G54238	57 a 59
19,9	87,8	4,31	7000	G54239	57 a 59
18,4	95,2	3,97	7000	G54240	57 a 59
16,1	109	3,47	7000	G54241	57 a 59
14,3	123	3,08	7000	G54242	57 a 59
12,7	138	2,74	7000	G54243	57 a 59
11,1	158	2,39	7000	G54244	57 a 59
9,35	187	2,02	7000	G54245	57 a 59
7,86	223	2,71	7000	G54247	57 a 59
6,96	251	2,40	7000	G54248	57 a 59
5,39	325	1,86	7000	G54250	57 a 59
5,00	350	1,72	7000	G54251	57 a 59
4,56	384	1,57	7000	G54252	57 a 59
5,03	347	3,48	8000	G56250	60 a 62
4,50	389	3,10	8000	G56251	60 a 62
4,03	434	2,78	8000	G56252	60 a 62
3,53	495	2,44	8000	G56253	60 a 62
3,26	537	2,25	8000	G56254	60 a 62
3,21	545	1,45	8000	G56455	75 a 77
2,99	586	1,35	8000	G56456	75 a 77
2,43	719	1,10	8000	G56457	75 a 77
2,13	820	0,96	8000	G56458	75 a 77
1,86	941	0,84	8000	G56459	75 a 77
3,15	555	3,08	9000	G58455	78 a 80
2,83	618	2,76	9000	G58456	78 a 80
2,54	689	2,48	9000	G58457	78 a 80



**0,25 kW - 1750 rpm**

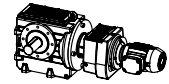

rpm	Itot	fs	Fr (N)	código	páginas
2,35	745	2,29	9000	G58458	78 a 80
1,94	901	1,90	9000	G58459	78 a 80
1,69	1,034	1,65	9000	G58460	78 a 80
1,52	1,154	1,48	9000	G58461	78 a 80
1,40	1,248	1,37	9000	G58462	78 a 80
1,29	1,355	1,26	9000	G58463	78 a 80
1,16	1,508	1,13	9000	G58464	78 a 80
1,00	1,744	0,98	9000	G58465	78 a 80
0,848	2,063	0,83	9000	G58466	78 a 80



**0,37 kW - 1750 rpm**

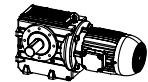

235	7,44	4,59	1600	G51218	51 a 53
197	8,90	5,18	1700	G51219	51 a 53
174	10,0	4,97	1800	G51220	51 a 53
161	10,9	5,00	2000	G51221	51 a 53
147	11,9	5,03	2200	G51222	51 a 53
127	13,7	4,37	2400	G51223	51 a 53
112	15,6	3,84	2500	G51224	51 a 53
99,3	17,6	3,40	2800	G51225	51 a 53
85,7	20,4	2,93	2900	G51226	51 a 53
81,3	21,5	3,20	3000	G51227	51 a 53
72,1	24,3	2,83	3000	G51228	51 a 53
60,8	28,8	2,39	3000	G51229	51 a 53
52,6	33,3	2,07	3000	G51230	51 a 53
46,2	37,9	1,82	3000	G51232	51 a 53
41,0	42,6	1,62	3000	G51233	51 a 53
35,4	49,4	1,39	3000	G51234	51 a 53
32,7	53,4	1,29	3000	G51235	51 a 53
29,7	59,0	1,17	3000	G51236	51 a 53
22,8	76,8	1,11	3000	G51238	51 a 53
19,7	88,7	0,96	3000	G51239	51 a 53
17,3	101	0,84	3000	G51240	51 a 53
85,6	20,5	5,26	3400	G52226	54 a 56
72,9	24,0	5,17	3500	G52228	54 a 56
63,9	27,4	4,52	3600	G52229	54 a 56
55,7	31,4	3,95	3800	G52230	54 a 56
47,8	36,6	3,39	4100	G52231	54 a 56



0,37 kW - 1750 rpm

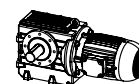



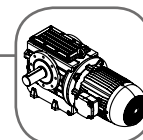

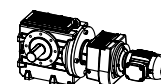

rpm	ítot	fs	Fr (N)	código	páginas
41,9	41,7	2,97	4300	G52232	54 a 56
37,1	47,1	2,63	4500	G52233	54 a 56
33,1	52,9	2,34	5000	G52235	54 a 56
28,7	60,9	2,04	5000	G52236	54 a 56
24,3	72,0	1,72	5000	G52237	54 a 56
20,9	83,8	1,83	5000	G52238	54 a 56
19,4	90,0	1,70	5000	G52239	54 a 56
17,9	97,6	1,57	5000	G52240	54 a 56
15,7	111	1,38	5000	G52241	54 a 56
13,9	126	1,22	5000	G52242	54 a 56
12,4	141	1,09	5000	G52243	54 a 56
10,8	162	0,95	5000	G52244	54 a 56
10,00	175	0,88	5000	G52245	54 a 56
7,86	223	1,10	5000	G52247	54 a 56
6,96	251	0,97	5000	G52248	54 a 56
35,9	48,7	4,24	7000	G54234	57 a 59
32,0	54,7	3,78	7000	G54235	57 a 59
27,8	62,9	3,28	7000	G54236	57 a 59
23,5	74,4	2,78	7000	G54237	57 a 59
21,4	81,7	3,13	7000	G54238	57 a 59
19,9	87,8	2,91	7000	G54239	57 a 59
18,4	95,2	2,69	7000	G54240	57 a 59
16,1	109	2,35	7000	G54241	57 a 59
14,3	123	2,08	7000	G54242	57 a 59
12,7	138	1,85	7000	G54243	57 a 59
11,1	158	1,62	7000	G54244	57 a 59
9,35	187	1,37	7000	G54245	57 a 59
7,86	223	1,83	7000	G54247	57 a 59
6,96	251	1,62	7000	G54248	57 a 59
5,39	325	1,25	7000	G54250	57 a 59
5,00	350	1,16	7000	G54251	57 a 59
4,56	384	1,06	7000	G54252	57 a 59
13,4	131	3,90	8000	G56242	60 a 62
12,5	140	3,65	8000	G56243	60 a 62
11,1	158	3,24	8000	G56244	60 a 62
9,92	176	2,90	8000	G56245	60 a 62
8,88	197	2,60	8000	G56246	60 a 62



**0,37 kW - 1750 rpm**



rpm	ítot	fs	Fr (N)	código	páginas
					
7,20	243	3,35	8000	G56247	60 a 62
6,07	288	2,83	8000	G56248	60 a 62
5,03	347	2,35	8000	G56250	60 a 62
4,50	389	2,10	8000	G56251	60 a 62
4,03	434	1,88	8000	G56252	60 a 62
3,53	495	1,65	8000	G56253	60 a 62
3,26	537	1,52	8000	G56254	60 a 62
4,23	414	4,27	9000	G58252	63 a 65
3,80	461	3,83	9000	G58253	63 a 65
3,38	518	3,41	9000	G58254	63 a 65
3,21	545	0,98	8000	G56455	75 a 77
2,99	586	0,91	8000	G56456	75 a 77
3,15	555	2,08	9000	G58455	78 a 80
2,83	618	1,87	9000	G58456	78 a 80
2,54	689	1,67	9000	G58457	78 a 80
2,35	745	1,55	9000	G58458	78 a 80
1,94	901	1,28	9000	G58459	78 a 80
1,69	1,034	1,12	9000	G58460	78 a 80
1,52	1,154	1,00	9000	G58461	78 a 80
1,40	1,248	0,92	9000	G58462	78 a 80
1,29	1,355	0,85	9000	G58463	78 a 80
1,16	1,508	0,77	9000	G58464	78 a 80



**0,55 kW - 1750 rpm**

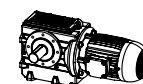





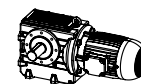

235	7,44	3,09	1600	G51218	51 a 53
197	8,90	3,48	1700	G51219	51 a 53
174	10,0	3,34	1800	G51220	51 a 53
161	10,9	3,36	2000	G51221	51 a 53
147	11,9	3,38	2200	G51222	51 a 53
127	13,7	2,94	2400	G51223	51 a 53
112	15,6	2,58	2500	G51224	51 a 53
99,3	17,6	2,29	2800	G51225	51 a 53
85,7	20,4	1,97	2900	G51226	51 a 53
81,3	21,5	2,15	3000	G51227	51 a 53
72,1	24,3	1,91	3000	G51228	51 a 53
60,8	28,8	1,61	3000	G51229	51 a 53
52,6	33,3	1,39	3000	G51230	51 a 53



## 0,55 kW - 1750 rpm



rpm	ítot	fs	Fr (N)	código	páginas
					
46,2	37,9	1,22	3000	G51232	51 a 53
41,0	42,6	1,09	3000	G51233	51 a 53
35,4	49,4	0,94	3000	G51234	51 a 53
32,7	53,4	0,87	3000	G51235	51 a 53
124	14,2	5,10	2700	G52223	54 a 56
108	16,1	4,50	2800	G52224	54 a 56
96,0	18,2	3,98	3100	G52225	54 a 56
85,6	20,5	3,54	3400	G52226	54 a 56
72,9	24,0	3,47	3500	G52228	54 a 56
63,9	27,4	3,04	3600	G52229	54 a 56
55,7	31,4	2,66	3800	G52230	54 a 56
47,8	36,6	2,28	4100	G52231	54 a 56
41,9	41,7	2,00	4300	G52232	54 a 56
37,1	47,1	1,77	4500	G52233	54 a 56
33,1	52,9	1,58	5000	G52235	54 a 56
28,7	60,9	1,37	5000	G52236	54 a 56
24,3	72,0	1,16	5000	G52237	54 a 56
20,9	83,8	1,23	5000	G52238	54 a 56
19,4	90,0	1,15	5000	G52239	54 a 56
17,9	97,6	1,06	5000	G52240	54 a 56
15,7	111	0,93	5000	G52241	54 a 56
13,9	126	0,82	5000	G52242	54 a 56
53,9	32,5	4,28	6400	G54230	57 a 59
50,2	34,9	3,98	6600	G54231	57 a 59
46,3	37,8	3,68	7000	G54232	57 a 59
40,6	43,1	3,22	7000	G54233	57 a 59
35,9	48,7	2,85	7000	G54234	57 a 59
32,0	54,7	2,54	7000	G54235	57 a 59
27,8	62,9	2,21	7000	G54236	57 a 59
23,5	74,4	1,87	7000	G54237	57 a 59
21,4	81,7	2,10	7000	G54238	57 a 59
19,9	87,8	1,96	7000	G54239	57 a 59
18,4	95,2	1,81	7000	G54240	57 a 59
16,1	109	1,58	7000	G54241	57 a 59
14,3	123	1,40	7000	G54242	57 a 59
12,7	138	1,25	7000	G54243	57 a 59
11,1	158	1,09	7000	G54244	57 a 59





**0,55 kW - 1750 rpm**

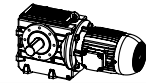

rpm	Itot	fs	Fr (N)	código	páginas
9,35	187	0,92	7000	G54245	57 a 59
7,86	223	1,23	7000	G54247	57 a 59
6,96	251	1,09	7000	G54248	57 a 59
5,39	325	0,84	7000	G54250	57 a 59
17,8	98,3	3,50	8000	G56240	60 a 62
15,9	110	3,13	8000	G56241	60 a 62
13,4	131	2,63	8000	G56242	60 a 62
12,5	140	2,46	8000	G56243	60 a 62
11,1	158	2,18	8000	G56244	60 a 62
9,92	176	1,95	8000	G56245	60 a 62
8,88	197	1,75	8000	G56246	60 a 62
7,20	243	2,26	8000	G56247	60 a 62
6,07	288	1,90	8000	G56248	60 a 62
5,03	347	1,58	8000	G56250	60 a 62
4,50	389	1,41	8000	G56251	60 a 62
4,03	434	1,26	8000	G56252	60 a 62
3,53	495	1,11	8000	G56253	60 a 62
3,26	537	1,02	8000	G56254	60 a 62
11,8	148	5,04	9000	G58244	63 a 65
9,43	186	4,01	9000	G58245	63 a 65
8,46	207	3,60	9000	G58246	63 a 65
7,74	226	5,26	9000	G58247	63 a 65
6,59	266	4,47	9000	G58248	63 a 65
5,92	296	4,01	9000	G58250	63 a 65
5,03	348	3,41	9000	G58251	63 a 65
4,23	414	2,87	9000	G58252	63 a 65
3,80	461	2,58	9000	G58253	63 a 65
3,38	518	2,29	9000	G58254	63 a 65
3,15	555	1,40	9000	G58455	78 a 80
2,83	618	1,26	9000	G58456	78 a 80
2,54	689	1,13	9000	G58457	78 a 80
2,35	745	1,04	9000	G58458	78 a 80
1,94	901	0,86	9000	G58459	78 a 80



**0,75 kW - 1750 rpm**

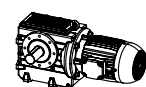





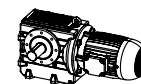

235	7,44	2,26	1600	G51218	51 a 53
197	8,90	2,55	1700	G51219	51 a 53



## 0,75 kW - 1750 rpm







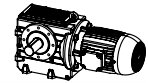

rpm	ítot	fs	Fr (N)	código	páginas
 174	 10,0	 2,45	 1800	 G51220	 51 a 53
161	10,9	2,47	2000	G51221	51 a 53
147	11,9	2,48	2200	G51222	51 a 53
127	13,7	2,16	2400	G51223	51 a 53
112	15,6	1,89	2500	G51224	51 a 53
99,3	17,6	1,68	2800	G51225	51 a 53
85,7	20,4	1,45	2900	G51226	51 a 53
81,3	21,5	1,58	3000	G51227	51 a 53
72,1	24,3	1,40	3000	G51228	51 a 53
60,8	28,8	1,18	3000	G51229	51 a 53
52,6	33,3	1,02	3000	G51230	51 a 53
46,2	37,9	0,90	3000	G51232	51 a 53
231	7,57	4,29	2100	G52218	54 a 56
189	9,28	4,52	2200	G52219	54 a 56
165	10,6	4,51	2500	G52221	54 a 56
144	12,2	4,36	2600	G52222	54 a 56
124	14,2	3,74	2700	G52223	54 a 56
108	16,1	3,30	2800	G52224	54 a 56
96,0	18,2	2,92	3100	G52225	54 a 56
85,6	20,5	2,59	3400	G52226	54 a 56
72,9	24,0	2,55	3500	G52228	54 a 56
63,9	27,4	2,23	3600	G52229	54 a 56
55,7	31,4	1,95	3800	G52230	54 a 56
47,8	36,6	1,67	4100	G52231	54 a 56
41,9	41,7	1,47	4300	G52232	54 a 56
37,1	47,1	1,30	4500	G52233	54 a 56
33,1	52,9	1,16	5000	G52235	54 a 56
20,9	83,8	0,90	5000	G52238	54 a 56
19,4	90,0	0,84	5000	G52239	54 a 56
85,6	20,5	4,32	5300	G54226	57 a 59
70,6	24,8	4,11	5800	G54228	57 a 59
61,8	28,3	3,60	6000	G54229	57 a 59
53,9	32,5	3,14	6400	G54230	57 a 59
50,2	34,9	2,92	6600	G54231	57 a 59
46,3	37,8	2,70	7000	G54232	57 a 59
40,6	43,1	2,36	7000	G54233	57 a 59
35,9	48,7	2,09	7000	G54234	57 a 59







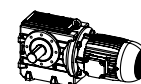

0,75 kW - 1750 rpm



rpm	Itot	fs	Fr (N)	código	páginas
					
32,0	54,7	1,86	7000	G54235	57 a 59
21,4	81,7	1,54	7000	G54238	57 a 59
19,9	87,8	1,44	7000	G54239	57 a 59
18,4	95,2	1,32	7000	G54240	57 a 59
16,1	109	1,16	7000	G54241	57 a 59
14,3	123	1,03	7000	G54242	57 a 59
12,7	138	0,91	7000	G54243	57 a 59
7,86	223	3,86	7000	G54247	57 a 59
6,96	251	0,80	7000	G54248	57 a 59
32,4	54,0	3,78	8000	G56235	60 a 62
28,9	60,7	3,36	8000	G56236	60 a 62
25,8	67,9	3,00	8000	G56237	60 a 62
21,1	83,1	3,04	8000	G56239	60 a 62
17,8	98,3	2,57	8000	G56240	60 a 62
15,9	110	2,29	8000	G56241	60 a 62
13,4	131	1,93	8000	G56242	60 a 62
12,5	140	1,80	8000	G56243	60 a 62
11,1	158	1,60	8000	G56244	60 a 62
9,92	176	1,43	8000	G56245	60 a 62
8,88	197	1,28	8000	G56246	60 a 62
7,20	243	1,66	8000	G56247	60 a 62
6,07	288	1,40	8000	G56248	60 a 62
5,03	347	1,16	8000	G56250	60 a 62
4,50	389	1,03	8000	G56251	60 a 62
4,03	434	0,93	8000	G56252	60 a 62
13,2	133	4,11	9000	G58243	63 a 65
11,8	148	3,69	9000	G58244	63 a 65
9,43	186	2,94	9000	G58245	63 a 65
8,46	207	2,64	9000	G58246	63 a 65
7,74	226	3,86	9000	G58247	63 a 65
6,59	266	3,28	9000	G58248	63 a 65
5,92	296	2,94	9000	G58250	63 a 65
5,03	348	2,50	9000	G58251	63 a 65
4,23	414	2,10	9000	G58252	63 a 65
3,80	461	1,89	9000	G58253	63 a 65
3,38	518	1,68	9000	G58254	63 a 65
3,15	555	1,03	9000	G58455	78 a 80

**0,75 kW - 1750 rpm**

rpm	ítot	fs	Fr (N)	código	páginas
 2,83	 618	 0,92	 9000	 G58456	 78 a 80
2,54	689	0,83	9000	G58457	78 a 80
2,35	745	0,76	9000	G58458	78 a 80

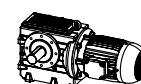
**1,10 kW - 1750 rpm**

235	7,44	1,54	1600	G51218	51 a 53
197	8,90	1,74	1700	G51219	51 a 53
174	10,0	1,67	1800	G51220	51 a 53
161	10,9	1,68	2000	G51221	51 a 53
147	11,9	1,69	2200	G51222	51 a 53
127	13,7	1,47	2400	G51223	51 a 53
112	15,6	1,29	2500	G51224	51 a 53
99,3	17,6	1,14	2800	G51225	51 a 53
81,3	21,5	1,08	3000	G51227	51 a 53
72,1	24,3	0,95	3000	G51228	51 a 53
60,8	28,8	0,80	3000	G51229	51 a 53
231	7,57	2,93	2100	G52218	54 a 56
189	9,28	3,08	2200	G52219	54 a 56
165	10,6	3,08	2500	G52221	54 a 56
144	12,2	2,97	2600	G52222	54 a 56
124	14,2	2,55	2700	G52223	54 a 56
108	16,1	2,25	2800	G52224	54 a 56
96,0	18,2	1,99	3100	G52225	54 a 56
85,6	20,5	1,77	3400	G52226	54 a 56
72,9	24,0	1,74	3500	G52228	54 a 56
63,9	27,4	1,52	3600	G52229	54 a 56
55,7	31,4	1,33	3800	G52230	54 a 56
47,8	36,6	1,14	4100	G52231	54 a 56
41,9	41,7	1,00	4300	G52232	54 a 56
37,1	47,1	0,89	4500	G52233	54 a 56
231	7,57	6,38	3700	G54218	57 a 59
189	9,28	6,51	3800	G54219	57 a 59
165	10,6	5,70	4500	G54221	57 a 59
144	12,2	4,95	4700	G54222	57 a 59
124	14,2	4,25	4800	G54223	57 a 59
108	16,1	3,75	5000	G54224	57 a 59



1,10 kW - 1750 rpm

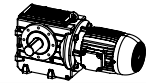





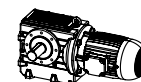

rpm	ítot	fs	Fr (N)	código	páginas
96,0	18,2	3,32	5200	G54225	57 a 59
85,6	20,5	2,95	5300	G54226	57 a 59
70,6	24,8	2,80	5800	G54228	57 a 59
61,8	28,3	2,46	6000	G54229	57 a 59
53,9	32,5	2,14	6400	G54230	57 a 59
50,2	34,9	1,99	6600	G54231	57 a 59
46,3	37,8	1,84	7000	G54232	57 a 59
40,6	43,1	1,61	7000	G54233	57 a 59
35,9	48,7	1,43	7000	G54234	57 a 59
32,0	54,7	1,27	7000	G54235	57 a 59
21,4	81,7	1,05	7000	G54238	57 a 59
19,9	87,8	0,98	7000	G54239	57 a 59
18,4	95,2	0,90	7000	G54240	57 a 59
46,3	37,8	3,68	8000	G56232	60 a 62
41,3	42,4	3,28	8000	G56233	60 a 62
34,8	50,3	2,76	8000	G56234	60 a 62
32,4	54,0	2,57	8000	G56235	60 a 62
28,9	60,7	2,29	8000	G56236	60 a 62
25,8	67,9	2,05	8000	G56237	60 a 62
21,1	83,1	2,07	8000	G56239	60 a 62
17,8	98,3	1,75	8000	G56240	60 a 62
15,9	110	1,56	8000	G56241	60 a 62
13,4	131	1,31	8000	G56242	60 a 62
12,5	140	1,23	8000	G56243	60 a 62
11,1	158	1,09	8000	G56244	60 a 62
9,92	176	0,98	8000	G56245	60 a 62
8,88	197	0,87	8000	G56246	60 a 62
7,20	243	1,13	8000	G56247	60 a 62
6,07	288	0,95	8000	G56248	60 a 62
30,6	57,3	5,26	9000	G58235	63 a 65
26,0	67,4	4,47	9000	G58236	63 a 65
24,3	71,9	4,19	9000	G58237	63 a 65
22,4	78,2	4,76	9000	G58238	63 a 65
20,4	85,7	4,35	9000	G58239	63 a 65
17,7	98,9	3,77	9000	G58240	63 a 65
15,5	113	3,30	9000	G58241	63 a 65
13,2	133	2,80	9000	G58243	63 a 65



## 2,20 kW - 1750 rpm



rpm	Itot	fs	Fr (N)	código	páginas
					
11,8	148	2,52	9000	G58244	63 a 65
9,43	186	2,00	9000	G58245	63 a 65
8,46	207	1,80	9000	G58246	63 a 65
7,74	226	2,63	9000	G58247	63 a 65
6,59	266	2,23	9000	G58248	63 a 65
5,92	296	2,01	9000	G58250	63 a 65
4,23	414	1,44	9000	G58252	63 a 65
3,80	461	1,29	9000	G58253	63 a 65
3,38	518	1,15	9000	G58254	63 a 65
3,15	555	0,70	9000	G58455	78 a 80



## 1,50 kW - 1750 rpm

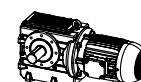

235	7,44	1,13	1600	G51218	51 a 53
197	8,90	1,28	1700	G51219	51 a 53
174	10,0	1,23	1800	G51220	51 a 53
161	10,9	1,23	2000	G51221	51 a 53
147	11,9	1,24	2200	G51222	51 a 53
127	13,7	1,08	2400	G51223	51 a 53
231	7,57	2,15	2100	G52218	54 a 56
189	9,28	2,26	2200	G52219	54 a 56
165	10,6	2,26	2500	G52221	54 a 56
144	12,2	2,18	2600	G52222	54 a 56
124	14,2	1,87	2700	G52223	54 a 56
108	16,1	1,65	2800	G52224	54 a 56
72,9	24,0	1,27	3500	G52228	54 a 56
63,9	27,4	1,12	3600	G52229	54 a 56
55,7	31,4	0,97	3800	G52230	54 a 56
47,8	36,6	0,84	4100	G52231	54 a 56
231	7,57	4,68	3700	G54218	57 a 59
189	9,28	4,77	3800	G54219	57 a 59
165	10,6	4,18	4500	G54221	57 a 59
144	12,2	3,63	4700	G54222	57 a 59
124	14,2	3,12	4800	G54223	57 a 59
108	16,1	2,75	5000	G54224	57 a 59
70,6	24,8	2,06	5800	G54228	57 a 59
61,8	28,3	1,80	6000	G54229	57 a 59





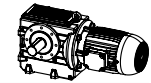

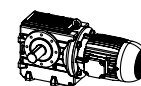

1,50 kW - 1750 rpm



rpm	Itot	fs	Fr (N)	código	páginas
53,9	32,5	1,57	6400	G54230	57 a 59
50,2	34,9	1,46	6600	G54231	57 a 59
46,3	37,8	1,35	7000	G54232	57 a 59
40,6	43,1	1,18	7000	G54233	57 a 59
90,1	19,4	4,57	5300	G56225	60 a 62
83,8	20,9	4,24	5500	G56226	60 a 62
76,6	22,9	4,45	5900	G56227	60 a 62
63,3	27,6	3,69	6300	G56229	60 a 62
46,3	37,8	2,70	8000	G56232	60 a 62
41,3	42,4	2,40	8000	G56233	60 a 62
34,8	50,3	2,03	8000	G56234	60 a 62
32,4	54,0	1,89	8000	G56235	60 a 62
28,9	60,7	1,68	8000	G56236	60 a 62
21,1	83,1	1,52	8000	G56239	60 a 62
17,8	98,3	1,28	8000	G56240	60 a 62
15,9	110	1,15	8000	G56241	60 a 62
13,4	131	0,96	8000	G56242	60 a 62
12,5	140	0,90	8000	G56243	60 a 62
7,20	243	0,83	8000	G56247	60 a 62
34,0	51,5	4,29	9000	G58234	63 a 65
30,6	57,3	3,85	9000	G58235	63 a 65
26,0	67,4	3,28	9000	G58236	63 a 65
24,3	71,9	3,07	9000	G58237	63 a 65
22,4	78,2	3,49	9000	G58238	63 a 65
20,4	85,7	3,19	9000	G58239	63 a 65
17,7	98,9	2,76	9000	G58240	63 a 65
15,5	113	2,42	9000	G58241	63 a 65
13,2	133	2,05	9000	G58243	63 a 65
11,8	148	1,85	9000	G58244	63 a 65
9,43	186	1,47	9000	G58245	63 a 65
8,46	207	1,32	9000	G58246	63 a 65
7,74	226	1,93	9000	G58247	63 a 65
6,59	266	1,64	9000	G58248	63 a 65
5,92	296	1,47	9000	G58250	63 a 65
5,03	348	1,25	9000	G58251	63 a 65
4,23	414	1,05	9000	G58252	63 a 65
3,80	461	0,95	9000	G58253	63 a 65

**3,00 kW - 1750 rpm**

rpm	ítot	fs	Fr (N)	código	páginas
 3,38	 518	 0,84	 9000	 G58254	 63 a 65

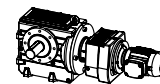
**2,20 kW - 1750 rpm**

197	8,90	0,87	1700	G51219	51 a 53
174	10,0	0,84	1800	G51220	51 a 53
161	10,9	0,84	2000	G51221	51 a 53
147	11,9	0,85	2200	G51222	51 a 53
231	7,57	1,46	2100	G52218	54 a 56
189	9,28	1,54	2200	G52219	54 a 56
165	10,6	1,54	2500	G52221	54 a 56
144	12,2	1,49	2600	G52222	54 a 56
124	14,2	1,28	2700	G52223	54 a 56
108	16,1	1,13	2800	G52224	54 a 56
72,9	24,0	0,87	3500	G52228	54 a 56
231	7,57	3,19	3700	G54218	57 a 59
189	9,28	3,25	3800	G54219	57 a 59
165	10,6	2,85	4500	G54221	57 a 59
144	12,2	2,48	4700	G54222	57 a 59
124	14,2	2,13	4800	G54223	57 a 59
108	16,1	1,88	5000	G54224	57 a 59
70,6	24,8	1,40	5800	G54228	57 a 59
61,8	28,3	1,23	6000	G54229	57 a 59
53,9	32,5	1,07	6400	G54230	57 a 59
50,2	34,9	1,00	6600	G54231	57 a 59
46,3	37,8	0,92	7000	G54232	57 a 59
40,6	43,1	0,81	7000	G54233	57 a 59
214	8,17	5,54	3800	G56218	60 a 62
198	8,84	5,47	4000	G56219	60 a 62
164	10,7	5,50	4100	G56220	60 a 62
142	12,4	4,87	4800	G56222	60 a 62
120	14,6	4,14	5100	G56223	60 a 62
107	16,4	3,68	5100	G56224	60 a 62
90,1	19,4	3,11	5300	G56225	60 a 62
83,8	20,9	2,89	5500	G56226	60 a 62
76,6	22,9	3,03	5900	G56227	60 a 62



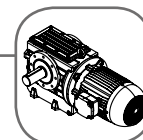

**2,20 kW - 1750 rpm**

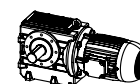

rpm	ítot	fs	Fr (N)	código	páginas
63,3	27,6	2,52	6300	G56229	60 a 62
46,3	37,8	1,84	8000	G56232	60 a 62
41,3	42,4	1,64	8000	G56233	60 a 62
34,8	50,3	1,38	8000	G56234	60 a 62
32,4	54,0	1,29	8000	G56235	60 a 62
28,9	60,7	1,14	8000	G56236	60 a 62
21,1	83,1	1,03	8000	G56239	60 a 62
17,8	98,3	0,87	8000	G56240	60 a 62
57,8	30,3	4,97	6700	G58230	63 a 65
52,7	33,2	4,54	7500	G58231	63 a 65
45,6	38,3	3,93	9000	G58232	63 a 65
40,0	43,8	3,44	9000	G58233	63 a 65
34,0	51,5	2,92	9000	G58234	63 a 65
30,6	57,3	2,63	9000	G58235	63 a 65
26,0	67,4	2,23	9000	G58236	63 a 65
24,3	71,9	2,09	9000	G58237	63 a 65
22,4	78,2	2,38	9000	G58238	63 a 65
20,4	85,7	2,17	9000	G58239	63 a 65
17,7	98,9	1,88	9000	G58240	63 a 65
15,5	113	1,65	9000	G58241	63 a 65
13,2	133	1,40	9000	G58243	63 a 65
11,8	148	1,26	9000	G58244	63 a 65
9,43	186	1,00	9000	G58245	63 a 65
8,46	207	0,90	9000	G58246	63 a 65
7,74	226	1,31	9000	G58247	63 a 65
6,59	266	1,12	9000	G58248	63 a 65
5,92	296	1,00	9000	G58250	63 a 65
5,03	348	0,85	9000	G58251	63 a 65



**3,00 kW - 1750 rpm**

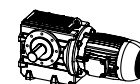

231	7,57	1,07	2100	G52218	54 a 56
189	9,28	1,13	2200	G52219	54 a 56
165	10,6	1,13	2500	G52221	54 a 56
144	12,2	1,09	2600	G52222	54 a 56
124	14,2	0,94	2700	G52223	54 a 56
231	7,57	2,34	3700	G54218	57 a 59



## 3,00 kW - 1750 rpm

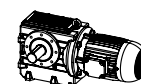





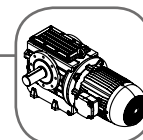

rpm	Ítot	fs	Fr (N)	código	páginas
189	9,28	2,39	3800	G54219	57 a 59
165	10,6	2,09	4500	G54221	57 a 59
144	12,2	1,82	4700	G54222	57 a 59
124	14,2	1,56	4800	G54223	57 a 59
70,6	24,8	1,03	5800	G54228	57 a 59
61,8	28,3	0,90	6000	G54229	57 a 59
214	8,17	4,07	3800	G56218	60 a 62
198	8,84	4,01	4000	G56219	60 a 62
164	10,7	4,04	4100	G56220	60 a 62
142	12,4	3,57	4800	G56222	60 a 62
120	14,6	3,03	5100	G56223	60 a 62
107	16,4	2,70	5100	G56224	60 a 62
90,1	19,4	2,28	5300	G56225	60 a 62
83,8	20,9	2,12	5500	G56226	60 a 62
76,6	22,9	2,23	5900	G56227	60 a 62
63,3	27,6	1,85	6300	G56229	60 a 62
46,3	37,8	1,35	8000	G56232	60 a 62
41,3	42,4	1,20	8000	G56233	60 a 62
34,8	50,3	1,01	8000	G56234	60 a 62
32,4	54,0	0,94	8000	G56235	60 a 62
81,6	21,4	5,16	5900	G58227	63 a 65
65,0	26,9	4,11	6500	G58229	63 a 65
57,8	30,3	3,64	6700	G58230	63 a 65
52,7	33,2	3,33	7500	G58231	63 a 65
45,6	38,3	2,88	9000	G58232	63 a 65
40,0	43,8	2,52	9000	G58233	63 a 65
34,0	51,5	2,14	9000	G58234	63 a 65
30,6	57,3	1,93	9000	G58235	63 a 65
26,0	67,4	1,64	9000	G58236	63 a 65
24,3	71,9	1,54	9000	G58237	63 a 65
22,4	78,2	1,75	9000	G58238	63 a 65
20,4	85,7	1,59	9000	G58239	63 a 65
17,7	98,9	1,38	9000	G58240	63 a 65
15,5	113	1,21	9000	G58241	63 a 65
13,2	133	1,03	9000	G58243	63 a 65
11,8	148	0,92	9000	G58244	63 a 65
7,74	226	0,96	9000	G58247	63 a 65

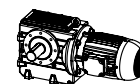
Obs.: Fatores de serviço para rotações inferiores a 1750 decrescem linearmente. Para rotações superiores, consulte-nos.



**3,00 kW - 1750 rpm**



rpm	Itot	fs	Fr (N)	código	páginas
 6,59	 266	 0,82	 9000	 G58248	 63 a 65



**3,70 kW - 1750 rpm**

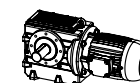

189	9,28	0,92	2200	G52219	54 a 56
165	10,6	0,91	2500	G52221	54 a 56
144	12,2	0,88	2600	G52222	54 a 56
231	7,57	1,90	3700	G54218	57 a 59
189	9,28	1,94	3800	G54219	57 a 59
165	10,6	1,69	4500	G54221	57 a 59
144	12,2	1,47	4700	G54222	57 a 59
124	14,2	1,26	4800	G54223	57 a 59
70,6	24,8	0,83	5800	G54228	57 a 59
214	8,17	3,30	3800	G56218	60 a 62
198	8,84	3,25	4000	G56219	60 a 62
164	10,7	3,27	4100	G56220	60 a 62
142	12,4	2,90	4800	G56222	60 a 62
120	14,6	2,46	5100	G56223	60 a 62
107	16,4	2,19	5100	G56224	60 a 62
90,1	19,4	1,85	5300	G56225	60 a 62
83,8	20,9	1,72	5500	G56226	60 a 62
76,6	22,9	1,80	5900	G56227	60 a 62
63,3	27,6	1,50	6300	G56229	60 a 62
46,3	37,8	1,09	8000	G56232	60 a 62
41,3	42,4	0,97	8000	G56233	60 a 62
34,8	50,3	0,82	8000	G56234	60 a 62
229	7,63	6,59	4000	G58218	63 a 65
190	9,21	6,56	4200	G58219	63 a 65
174	10,1	6,52	4300	G58220	63 a 65
154	11,3	6,57	4500	G58221	63 a 65
141	12,4	6,28	4900	G58222	63 a 65
122	14,3	5,44	5300	G58223	63 a 65
107	16,4	4,74	5400	G58224	63 a 65
90,9	19,3	4,03	5500	G58226	63 a 65
81,6	21,4	4,18	5900	G58227	63 a 65
65,0	26,9	3,33	6500	G58229	63 a 65

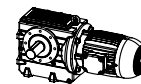
**3,70 kW - 1750 rpm**

rpm	ítot	fs	Fr (N)	código	páginas
57,8	30,3	2,95	6700	G58230	63 a 65
52,7	33,2	2,70	7500	G58231	63 a 65
45,6	38,3	2,34	9000	G58232	63 a 65
40,0	43,8	2,04	9000	G58233	63 a 65
34,0	51,5	1,74	9000	G58234	63 a 65
30,6	57,3	1,56	9000	G58235	63 a 65
26,0	67,4	1,33	9000	G58236	63 a 65
24,3	71,9	1,25	9000	G58237	63 a 65
22,4	78,2	1,42	9000	G58238	63 a 65
20,4	85,7	1,29	9000	G58239	63 a 65
17,7	98,9	1,12	9000	G58240	63 a 65
15,5	113	0,98	9000	G58241	63 a 65
13,2	133	0,83	9000	G58243	63 a 65

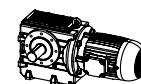
**4,50 kW - 1750 rpm**

231	7,57	1,56	3700	G54218	57 a 59
189	9,28	1,59	3800	G54219	57 a 59
165	10,6	1,39	4500	G54221	57 a 59
144	12,2	1,21	4700	G54222	57 a 59
198	8,84	2,67	4000	G56219	60 a 62
164	10,7	2,69	4100	G56220	60 a 62
142	12,4	2,38	4800	G56222	60 a 62
120	14,6	2,02	5100	G56223	60 a 62
107	16,4	1,80	5100	G56224	60 a 62
76,6	22,9	1,48	5900	G56227	60 a 62
63,3	27,6	1,23	6300	G56229	60 a 62
46,3	37,8	0,90	8000	G56232	60 a 62
41,3	42,4	0,80	8000	G56233	60 a 62
229	7,63	5,42	4000	G58218	63 a 65
190	9,21	5,40	4200	G58219	63 a 65
174	10,1	5,36	4300	G58220	63 a 65
154	11,3	5,40	4500	G58221	63 a 65
141	12,4	5,16	4900	G58222	63 a 65
122	14,3	4,47	5300	G58223	63 a 65
107	16,4	3,90	5400	G58224	63 a 65
90,9	19,3	3,32	5500	G58226	63 a 65

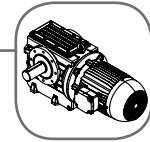

**4,50 kW - 1750 rpm**

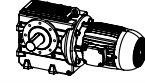

rpm	ítot	fs	Fr (N)	código	páginas
81,6	21,4	3,44	5900	G58227	63 a 65
65,0	26,9	2,74	6500	G58229	63 a 65
57,8	30,3	2,43	6700	G58230	63 a 65
52,7	33,2	2,22	7500	G58231	63 a 65
45,6	38,3	1,92	9000	G58232	63 a 65
40,0	43,8	1,68	9000	G58233	63 a 65
34,0	51,5	1,43	9000	G58234	63 a 65
30,6	57,3	1,28	9000	G58235	63 a 65
22,4	78,2	1,16	9000	G58238	63 a 65
20,4	85,7	1,06	9000	G58239	63 a 65
17,7	98,9	0,92	9000	G58240	63 a 65
15,5	113	0,81	9000	G58241	63 a 65



**5,50 kW - 1750 rpm**

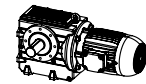

231	7,57	1,28	3700	G54218	57 a 59
189	9,28	1,30	3800	G54219	57 a 59
165	10,6	1,14	4500	G54221	57 a 59
144	12,2	0,99	4700	G54222	57 a 59
214	8,17	2,22	3800	G56218	60 a 62
198	8,84	2,19	4000	G56219	60 a 62
164	10,7	2,20	4100	G56220	60 a 62
142	12,4	1,95	4800	G56222	60 a 62
120	14,6	1,65	5100	G56223	60 a 62
107	16,4	1,47	5100	G56224	60 a 62
76,6	22,9	1,21	5900	G56227	60 a 62
63,3	27,6	1,01	6300	G56229	60 a 62
229	7,63	4,43	4000	G58218	63 a 65
190	9,21	4,42	4200	G58219	63 a 65
174	10,1	4,39	4300	G58220	63 a 65
154	11,3	4,42	4500	G58221	63 a 65
141	12,4	4,22	4900	G58222	63 a 65
122	14,3	3,66	5300	G58223	63 a 65
107	16,4	3,19	5400	G58224	63 a 65
90,9	19,3	2,71	5500	G58226	63 a 65
81,6	21,4	2,81	5900	G58227	63 a 65
65,0	26,9	2,24	6500	G58229	63 a 65

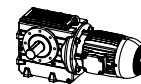
**5,50 kW - 1750 rpm**

rpm	Itot	fs	Fr (N)	código	páginas
57,8	30,3	1,99	6700	G58230	63 a 65
52,7	33,2	1,81	7500	G58231	63 a 65
45,6	38,3	1,57	9000	G58232	63 a 65
40,0	43,8	1,38	9000	G58233	63 a 65
34,0	51,5	1,17	9000	G58234	63 a 65
30,6	57,3	1,05	9000	G58235	63 a 65
22,4	78,2	2,81	9000	G58238	63 a 65
20,4	85,7	0,87	9000	G58239	63 a 65

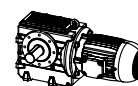
**7,50 kW - 1750 rpm**

231	7,57	0,94	3700	G54218	57 a 59
189	9,28	0,95	3800	G54219	57 a 59
165	10,6	0,84	4500	G54221	57 a 59
214	8,17	1,63	3800	G56218	60 a 62
198	8,84	3,24	4000	G56219	60 a 62
164	10,7	1,61	4100	G56220	60 a 62
142	12,4	1,43	4800	G56222	60 a 62
120	14,6	1,21	5100	G56223	60 a 62
107	16,4	1,08	5100	G56224	60 a 62
76,6	22,9	0,89	5900	G56227	60 a 62
229	7,63	3,25	4000	G58218	63 a 65
190	9,21	3,24	4200	G58219	63 a 65
174	10,1	3,22	4300	G58220	63 a 65
154	11,3	3,24	4500	G58221	63 a 65
141	12,4	3,10	4900	G58222	63 a 65
122	14,3	2,68	5300	G58223	63 a 65
107	16,4	2,34	5400	G58224	63 a 65
90,9	19,3	1,99	5500	G58226	63 a 65
81,6	21,4	2,06	5900	G58227	63 a 65
65,0	26,9	1,64	6500	G58229	63 a 65
57,8	30,3	1,46	6700	G58230	63 a 65
52,7	33,2	1,33	7500	G58231	63 a 65
45,6	38,3	1,15	9000	G58232	63 a 65
40,0	43,8	1,01	9000	G58233	63 a 65
34,0	51,5	0,86	9000	G58234	63 a 65



**9,20 kW - 1750 rpm**

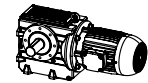

rpm	ítot	fs	Fr (N)	código	páginas
214	8,17	1,33	3800	G56218	60 a 62
198	8,84	1,31	4000	G56219	60 a 62
164	10,7	1,32	4100	G56220	60 a 62
142	12,4	1,16	4800	G56222	60 a 62
120	14,6	0,99	5100	G56223	60 a 62
107	16,4	0,88	5100	G56224	60 a 62
229	7,63	2,65	4000	G58218	63 a 65
190	9,21	2,64	4200	G58219	63 a 65
174	10,1	2,62	4300	G58220	63 a 65
154	11,3	2,64	4500	G58221	63 a 65
141	12,4	2,52	4900	G58222	63 a 65
122	14,3	2,19	5300	G58223	63 a 65
107	16,4	1,91	5400	G58224	63 a 65
90,9	19,3	1,62	5500	G58226	63 a 65
81,6	21,4	1,68	5900	G58227	63 a 65
65,0	26,9	1,34	6500	G58229	63 a 65
57,8	30,3	1,19	6700	G58230	63 a 65
52,7	33,2	1,08	7500	G58231	63 a 65
45,6	38,3	0,94	9000	G58232	63 a 65
40,0	43,8	0,82	9000	G58233	63 a 65





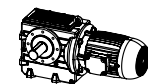

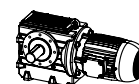

**11,00 kW - 1750 rpm**



214	8,17	1,11	3800	G56218	60 a 62
198	8,84	1,09	4000	G56219	60 a 62
164	10,7	1,10	4100	G56220	60 a 62
142	12,4	0,97	4800	G56222	60 a 62
120	14,6	0,83	5100	G56223	60 a 62
229	7,63	2,22	4000	G58218	63 a 65
190	9,21	2,21	4200	G58219	63 a 65
174	10,1	2,19	4300	G58220	63 a 65
154	11,3	2,21	4500	G58221	63 a 65
141	12,4	2,11	4900	G58222	63 a 65
122	14,3	1,83	5300	G58223	63 a 65
107	16,4	1,60	5400	G58224	63 a 65
90,9	19,3	1,36	5500	G58226	63 a 65
81,6	21,4	1,41	5900	G58227	63 a 65

**11,00 kW - 1750 rpm**

rpm	Itot	fs	Fr (N)	código	páginas
					
65,0	26,9	1,12	6500	G58229	63 a 65
57,8	30,3	0,99	6700	G58230	63 a 65
52,7	33,2	0,91	7500	G58231	63 a 65

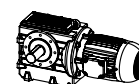
**15,00 kW - 1750 rpm**

164	10,7	0,81	4100	G56220	60 a 62
229	7,63	1,63	4000	G58218	63 a 65
190	9,21	1,62	4200	G58219	63 a 65
174	10,1	1,61	4300	G58220	63 a 65
154	11,3	1,62	4500	G58221	63 a 65
141	12,4	1,55	4900	G58222	63 a 65
122	14,3	1,34	5300	G58223	63 a 65
65,0	26,9	0,82	6500	G58229	63 a 65

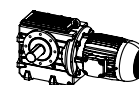
**18,50 kW - 1750 rpm**

229	7,63	1,32	4000	G58218	63 a 65
190	9,21	1,31	4200	G58219	63 a 65
174	10,1	1,30	4300	G58220	63 a 65
154	11,3	1,31	4500	G58221	63 a 65
141	12,4	1,26	4900	G58222	63 a 65
122	14,3	1,09	5300	G58223	63 a 65



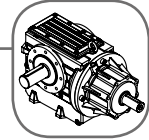

Nas tabelas de características técnicas, a rotação máxima é válida para motorredutores.

Para redutores com mancal a rotação máxima é 1800 rpm ou o valor da coluna rpm.max caso este for inferior a 1800 rpm.

Para rotações abaixo de 1750 rpm a potência admissível pode ser obtida com uma regra de 3 simples.

Para rotações acima de 1750 rpm até o limite máximo admissível obtido nas tabelas de Características Técnicas (págs. 41 a 49), deve ser utilizado o fator conforme abaixo:

nx	fn
3600	1,54
3200	1,43
3000	1,38
2800	1,32
2500	1,23
2200	1,14
2000	1,08

### Exemplo:

Redutor: G51232

Redução: 37,9

Potência: 0,673 kW

Rotação de entrada: 1750

Rotação de saída: 46,2

Rotação desejada: 74

Rotação de entrada: 2800

Redução encontrada: 37,9

Rotação de saída (corrigida): 73,8

$$P_{2800} = 0,673 \times 1,32 = 0,888 \text{ kW}$$

$$P_x = P_n \cdot f_n$$

$P_x$  = Potência na rotação  $n_x$

$P_n$  = Potência nominal a 1750 rpm (Tabelas nas págs. 37 a 45)

$f_n$  = Fator da rotação  $n_x$

**\*Para rotação de entrada abaixo de 100 rpm a lubrificação do redutor pode ficar prejudicada, neste caso solicitamos consultar a Cestari.**



### 57 - 100 Nm

### 51



rpm	ítot	kW	Mt (Nm)	Fr (N)	rpm.máx	$\eta\%$	código	carcaça*
235	7,44	1,70	57	1600	3000	82,74	G51218	63-100
197	8,9	1,92	77	1700	3000	82,74	G51219	63-100
175	10	1,84	83	1800	3000	82,74	G51220	63-100
161	10,9	1,85	91	2000	3000	82,74	G51221	63-100
147	11,9	1,86	100	2200	3000	82,74	G51222	63-100
128	13,7	1,62	100	2400	3000	82,74	G51223	63-90
112	15,6	1,42	100	2500	3000	82,74	G51224	63-80
99,4	17,6	1,26	100	2800	3000	82,74	G51225	63-80
85,8	20,4	1,09	100	2900	3000	82,74	G51226	63-71
81,4	21,5	1,19	100	3000	3000	71,91	G51227	63-100
72,0	24,3	1,05	100	3000	3000	71,91	G51228	63-100
60,8	28,8	0,885	100	3000	3000	71,91	G51229	63-100
52,6	33,3	0,765	100	3000	3000	71,91	G51230	63-90
46,2	37,9	0,672	100	3000	3000	71,91	G51232	63-80
41,1	42,6	0,598	100	3000	3000	71,91	G51233	63-80
35,4	49,4	0,516	100	3000	3000	71,91	G51234	63-71
32,8	53,4	0,477	100	3000	3000	71,91	G51235	63-71
29,7	59	0,432	100	3000	3000	71,91	G51236	63-71
22,8	76,8	0,411	100	3000	3000	58,12	G51238	63-100
19,7	88,7	0,355	100	3000	3000	58,12	G51239	63-90
17,3	101	0,312	100	3000	3000	58,12	G51240	63-80
15,4	114	0,277	100	3000	3000	58,12	G51241	63-80
13,3	132	0,239	100	3000	3000	58,12	G51242	63-71
12,2	143	0,220	100	3000	3000	58,12	G51243	63-71
11,1	157	0,201	100	3000	3000	58,12	G51244	63-71
9,89	177	0,178	100	3000	3000	58,12	G51245	63-90
8,66	202	0,156	100	3000	3000	58,12	G51246	63-80
7,71	227	0,221	100	3000	3000	36,45	G51247	63-80
6,63	264	0,190	100	3000	3000	36,45	G51248	63-71
5,56	315	0,160	100	3000	3000	36,45	G51250	63-71



### 140 Nm

### 51

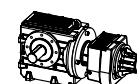

5,06	346	0,077	100	3000	3000	69,03	G51451	63-100
4,43	395	0,067	100	3000	3000	69,03	G51452	63-100
3,86	453	0,059	100	3000	3000	69,03	G51453	63-100
3,59	487	0,055	100	3000	3000	69,03	G51454	63-100
3,07	570	0,058	100	3000	3000	55,79	G51455	63-100
2,69	650	0,051	100	3000	3000	55,79	G51456	63-100
2,35	746	0,044	100	3000	3000	55,79	G51457	63-100

\* Verificar limites motor / redutor na página 77

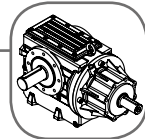

140 Nm

51

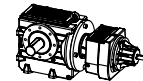

rpm	ítot	kW	Mt (Nm)	Fr (N)	rpm.máx	$\eta\%$	código	carcaça*
2,18	801	0,041	100	3000	3000	55,79	G51458	63-100
2,07	847	0,039	100	3000	3000	55,79	G51459	63-100
1,68	1.039	0,032	100	3000	3000	55,79	G51460	63-100
1,48	1.186	0,028	100	3000	3000	55,79	G51461	63-100
1,29	1.361	0,024	100	3000	3000	55,79	G51462	63-100
1,20	1.462	0,022	100	3000	3000	55,79	G51463	63-100
1,10	1.585	0,021	100	3000	3000	55,79	G51464	63-100
0,968	1.808	0,018	100	3000	3000	55,79	G51465	63-90
0,857	2.042	0,016	100	3000	3000	55,79	G51466	63-80
0,764	2.291	0,014	100	3000	3000	55,79	G51467	63-80
0,664	2.637	0,012	100	3000	3000	55,79	G51468	63-71
0,616	2.842	0,012	100	3000	3000	55,79	G51469	63-71
0,561	3.118	0,011	100	3000	3000	55,79	G51470	63-71
0,485	3.611	0,009	100	3000	3000	54,63	G51571	63-100
0,455	3.846	0,009	100	3000	3000	54,63	G51572	63-100
0,381	4.598	0,007	100	3000	3000	54,63	G51573	63-100
0,337	5.189	0,006	100	3000	3000	54,63	G51574	63-100
0,312	5.608	0,006	100	3000	3000	54,63	G51575	63-100
0,284	6.153	0,005	100	3000	3000	54,63	G51576	63-100
0,246	7.106	0,005	100	3000	3000	54,63	G51577	63-90
0,216	8.088	0,004	100	3000	3000	54,63	G51578	63-80
0,192	9.108	0,004	100	3000	3000	54,63	G51579	63-80
0,166	10.557	0,003	100	3000	3000	54,63	G51580	63-71
0,153	11.417	0,003	100	3000	3000	54,63	G51581	63-71
0,139	12.606	0,003	100	3000	3000	54,63	G51582	63-71



96 - 200 Nm

52

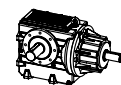

231	7,57	3,22	110	2100	2800	82,74	G52218	63-100
189	9,28	3,39	142	2200	2800	82,74	G52219	63-100
165	10,6	3,38	162	2500	2800	82,74	G52221	63-100
143	12,2	3,27	180	2600	2800	82,74	G52222	63-100
123	14,2	2,81	180	2700	2800	82,74	G52223	63-100
109	16,1	2,48	180	2800	2800	82,74	G52224	63-90
96,2	18,2	2,19	180	3100	2800	82,74	G52225	63-80
85,4	20,5	1,94	180	3400	2800	82,74	G52226	63-80
72,9	24,0	1,91	180	3500	2800	71,91	G52228	63-100
63,9	27,4	1,67	180	3600	2800	71,91	G52229	63-100
55,7	31,4	1,46	180	3800	2800	71,91	G52230	63-100

\* Verificar limites motor / redutor na página 77



96 - 200 Nm

52

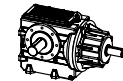

rpm	i <sub>tot</sub>	kW	Mt (Nm)	Fr (N)	rpm.máx	η%	código	carcaça*
47,8	36,6	1,25	180	4100	2800	71,91	G52231	63-100
42,0	41,7	1,10	180	4300	2800	71,91	G52232	63-90
37,2	47,1	0,97	180	4500	2800	71,91	G52233	63-80
33,1	52,9	0,867	180	5000	2800	71,91	G52235	63-80
28,7	60,9	0,753	180	5000	2800	71,91	G52236	63-71
24,3	72,0	0,637	180	5000	2800	71,91	G52237	63-71
20,9	83,8	0,677	180	5000	2800	58,12	G52238	63-100
19,4	90,0	0,631	180	5000	2800	58,12	G52239	63-100
17,9	97,6	0,581	180	5000	2800	58,12	G52240	63-100
15,8	111	0,511	180	5000	2800	58,12	G52241	63-90
13,9	126	0,450	180	5000	2800	58,12	G52242	63-80
12,4	141	0,402	180	5000	2800	58,12	G52243	63-80
10,8	162	0,350	180	5000	2800	58,12	G52244	63-71
10,00	175	0,324	180	5000	2800	58,12	G52245	63-71
9,11	192	0,296	180	5000	2800	58,12	G52246	63-71
7,85	223	0,406	180	5000	2800	36,45	G52247	63-90
6,97	251	0,361	180	5000	2800	36,45	G52248	63-80
5,38	325	0,278	180	5000	2800	36,45	G52250	63-71
5,00	350	0,259	180	5000	2800	36,45	G52251	63-71
4,56	384	0,236	180	5000	2800	36,45	G52252	63-71



200 Nm

52

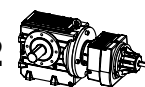

4,01	436	0,110	180	5000	2800	69,03	G52453	63-100
3,50	500	0,096	180	5000	2800	69,03	G52454	63-100
3,01	582	0,082	180	5000	2800	69,03	G52455	63-100
3,04	576	0,103	180	5000	2800	55,79	G52456	63-100
2,48	707	0,084	180	5000	2800	55,79	G52457	63-100
2,17	807	0,073	180	5000	2800	55,79	G52458	63-100
1,89	926	0,064	180	5000	2800	55,79	G52459	63-100
1,76	994	0,059	180	5000	2800	55,79	G52460	63-100
1,67	1.051	0,056	180	5000	2800	55,79	G52461	63-100
1,36	1.290	0,046	180	5000	2800	55,79	G52462	63-100
1,19	1.472	0,040	180	5000	2800	55,79	G52463	63-100
1,04	1.689	0,035	180	5000	2800	55,79	G52464	63-100
0,965	1.814	0,033	180	5000	2800	55,79	G52465	63-100
0,890	1.967	0,030	180	5000	2800	55,79	G52466	63-100
0,780	2.243	0,026	180	5000	2800	55,79	G52467	63-90
0,691	2.533	0,023	180	5000	2800	55,79	G52468	63-80
0,616	2.842	0,021	180	5000	2800	55,79	G52469	63-80

\* Verificar limites motor / reductor na página 77



200 Nm

52

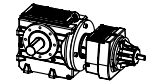

rpm	itot	kW	Mt (Nm)	Fr (N)	rpm.máx	$\eta\%$	código	carcaça*
0,535	3.271	0,018	180	5000	2800	55,79	G52470	63-71
0,496	3.526	0,017	180	5000	2800	55,79	G52471	63-71
0,452	3.869	0,015	180	5000	2800	55,79	G52472	63-71
0,391	4.480	0,013	180	5000	2800	54,63	G52573	63-100
0,367	4.772	0,013	180	5000	2800	54,63	G52574	63-100
0,307	5.705	0,011	180	5000	2800	54,63	G52575	63-100
0,272	6.438	0,009	180	5000	2800	54,63	G52576	63-100
0,251	6.959	0,009	180	5000	2800	54,63	G52577	63-100
0,229	7.635	0,008	180	5000	2800	54,63	G52578	63-100
0,198	8.817	0,007	180	5000	2800	54,63	G52579	63-90
0,174	10.036	0,006	180	5000	2800	54,63	G52580	63-80
0,155	11.301	0,005	180	5000	2800	54,63	G52581	63-80
0,134	13.099	0,005	180	5000	2800	54,63	G52582	63-71
0,124	14.166	0,004	180	5000	2800	54,63	G52583	63-71
0,112	15.640	0,004	180	5000	2800	54,63	G52584	63-71



222 - 450 Nm

54

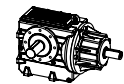

231	7,57	7,02	240	3700	2600	82,74	G54218	63-132
189	9,28	7,16	300	3800	2600	82,74	G54219	63-132
165	10,6	6,27	300	4500	2600	82,74	G54221	63-132
143	12,2	5,45	300	4700	2600	82,74	G54222	63-112
123	14,2	4,68	300	4800	2600	82,74	G54223	63-100
109	16,1	4,13	300	5000	2600	82,74	G54224	63-90
96,2	18,2	3,65	300	5200	2600	82,74	G54225	63-80
85,4	20,5	3,24	300	5300	2600	82,74	G54226	63-80
70,6	24,8	3,08	300	5800	2600	71,91	G54228	63-132
61,8	28,3	2,70	300	6000	2600	71,91	G54229	63-132
53,8	32,5	2,35	300	6400	2600	71,91	G54230	63-112
50,1	34,9	2,19	300	6600	2600	71,91	G54231	63-100
46,3	37,8	2,02	300	7000	2600	71,91	G54232	63-100
40,6	43,1	1,77	300	7000	2600	71,91	G54233	63-90
35,9	48,7	1,57	300	7000	2600	71,91	G54234	63-80
32,0	54,7	1,40	300	7000	2600	71,91	G54235	63-80
27,8	62,9	1,22	300	7000	2600	71,91	G54236	63-71
23,5	74,4	1,03	300	7000	2600	71,91	G54237	63-71
21,4	81,7	1,16	300	7000	2600	58,12	G54238	63-112
19,9	87,8	1,08	300	7000	2600	58,12	G54239	63-100

\* Verificar limites motor / redutor na página 77



222 - 450 Nm

54

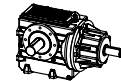

rpm	i <sub>tot</sub>	kW	Mt (Nm)	Fr (N)	rpm.máx	η%	código	carcaça*
18,4	95,2	0,99	300	7000	2600	58,12	G54240	63-100
16,1	109	0,87	300	7000	2600	58,12	G54241	63-90
14,2	123	0,77	300	7000	2600	58,12	G54242	63-80
12,7	138	1,69	300	7000	2600	58,12	G54243	63-80
11,1	158	0,599	300	7000	2600	58,12	G54244	63-71
9,36	187	0,506	300	7000	2600	58,12	G54245	63-71
7,85	223	0,68	300	7000	2600	36,45	G54247	63-90
6,97	251	0,601	300	7000	2600	36,45	G54248	63-80
5,38	325	0,464	300	7000	2600	36,45	G54250	63-71
5,00	350	0,431	300	7000	2600	36,45	G54251	63-71
4,56	384	0,393	300	7000	2600	36,45	G54252	63-71



450 Nm

54

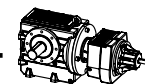

3,85	454	0,175	300	7000	2600	69,03	G54453	63-100
3,36	521	0,153	300	7000	2600	69,03	G54454	63-100
3,15	556	0,177	300	7000	2600	55,79	G54455	63-100
2,76	634	0,155	300	7000	2600	55,79	G54456	63-100
2,40	728	0,135	300	7000	2600	55,79	G54457	63-100
2,24	781	0,126	300	7000	2600	55,79	G54458	63-100
2,14	817	0,121	300	7000	2600	55,79	G54459	63-100
1,75	1.002	0,098	300	7000	2600	55,79	G54460	63-100
1,53	1.143	0,086	300	7000	2600	55,79	G54461	63-100
1,33	1.312	0,075	300	7000	2600	55,79	G54462	63-100
1,24	1.409	0,070	300	7000	2600	55,79	G54463	63-100
1,15	1.528	0,064	300	7000	2600	55,79	G54464	63-100
1,00	1.742	0,057	300	7000	2600	55,79	G54465	63-90
0,89	1.968	0,050	300	7000	2600	55,79	G54466	63-80
0,79	2.208	0,045	300	7000	2600	55,79	G54467	63-80
0,69	2.541	0,039	300	7000	2600	55,79	G54468	63-71
0,64	2.739	0,036	300	7000	2600	55,79	G54469	63-71
0,58	3.005	0,033	300	7000	2600	55,79	G54470	63-71
0,50	3.480	0,029	300	7000	2600	54,63	G54571	63-100
0,47	3.706	0,027	300	7000	2600	54,63	G54572	63-100
0,39	4.432	0,023	300	7000	2600	54,63	G54573	63-100
0,35	5.001	0,020	300	7000	2600	54,63	G54574	63-100
0,32	5.405	0,019	300	7000	2600	54,63	G54575	63-100
0,30	5.930	0,017	300	7000	2600	54,63	G54576	63-100
0,26	6.849	0,015	300	7000	2600	54,63	G54577	63-90

\* Verificar limites motor / redutor na página 77

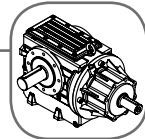

**450 Nm**

**54**

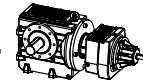

rpm	i <sub>tot</sub>	kW	Mt (Nm)	Fr (N)	rpm.máx	η%	código	carcaça*
0,22	7.795	0,013	300	7000	2600	54,63	G54578	63-80
0,20	8.778	0,011	300	7000	2600	54,63	G54579	63-80
0,17	10.175	0,010	300	7000	2600	54,63	G54580	63-71
0,16	11.003	0,009	300	7000	2600	54,63	G54581	63-71
0,14	12.149	0,008	300	7000	2600	54,63	G54582	63-71



**370 - 820 Nm**

**56**



214	8,17	12,2	450	3800	2500	82,74	G56218	63-160
198	8,84	12,0	480	4000	2500	82,74	G56219	63-160
164	10,7	12,1	585	4100	2500	82,74	G56220	63-160
141	12,4	10,7	600	4800	2500	82,74	G56222	63-132
120	14,6	9,1	600	5100	2500	82,74	G56223	63-132
107	16,4	8,1	600	5100	2500	82,74	G56224	63-132
90,2	19,4	6,85	600	5300	2500	82,74	G56225	63-100
83,7	20,9	6,36	600	5500	2500	82,74	G56226	63-100
76,4	22,9	6,68	600	5900	2500	71,91	G56227	63-160
63,4	27,6	5,54	600	6300	2500	71,91	G56229	63-160
46,3	37,8	4,04	600	8000	2500	71,91	G56232	63-132
41,3	42,4	3,61	600	8000	2500	71,91	G56233	63-132
34,8	50,3	3,04	600	8000	2500	71,91	G56234	63-100
32,4	54,0	2,83	600	8000	2500	71,91	G56235	63-100
28,8	60,7	2,52	600	8000	2500	71,91	G56236	63-90
25,8	67,9	2,25	600	8000	2500	71,91	G56237	63-80
21,1	83,1	2,28	600	8000	2500	58,12	G56239	63-132
17,8	98,3	1,92	600	8000	2500	58,12	G56240	63-132
15,9	110	1,72	600	8000	2500	58,12	G56241	63-132
13,4	131	1,44	600	8000	2500	58,12	G56242	63-100
12,5	140	1,35	600	8000	2500	58,12	G56243	63-100
11,1	158	1,20	600	8000	2500	58,12	G56244	63-90
9,94	176	1,07	600	8000	2500	58,12	G56245	63-80
8,88	197	0,96	600	8000	2500	58,12	G56246	63-80
7,20	243	1,24	600	8000	2500	36,45	G56247	63-132
6,08	288	1,05	600	8000	2500	36,45	G56248	63-100
5,04	347	0,87	600	8000	2500	36,45	G56250	63-90
4,50	389	0,78	600	8000	2500	36,45	G56251	63-80
4,03	434	0,695	600	8000	2500	36,45	G56252	63-80
3,54	495	0,609	600	8000	2500	36,45	G56253	63-71
3,26	537	0,562	600	8000	2500	36,45	G56254	63-71

\* Verificar limites motor / redutor na página 77



820 - 823 Nm

56

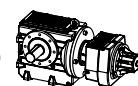

rpm	itot	<b>kW</b>	Mt (Nm)	Fr (N)	rpm.máx	<b>η%</b>	código	carcaça*
3,21	545	0,362	600	8000	2500	55,79	G56455	63-100
2,99	586	0,336	600	8000	2500	55,79	G56456	63-100
2,43	719	0,274	600	8000	2500	55,79	G56457	63-100
2,13	820	0,240	600	8000	2500	55,79	G56458	63-100
1,86	941	0,209	600	8000	2500	55,79	G56459	63-100
1,73	1.011	0,195	600	8000	2500	55,79	G56460	63-100
1,66	1.057	0,186	600	8000	2500	55,79	G56461	63-100
1,35	1.296	0,152	600	8000	2500	55,79	G56462	63-100
1,18	1.479	0,133	600	8000	2500	55,79	G56463	63-100
1,03	1.697	0,116	600	8000	2500	55,79	G56464	63-100
0,960	1.823	0,108	600	8000	2500	55,79	G56465	63-100
0,886	1.976	0,100	600	8000	2500	55,79	G56466	63-100
0,776	2.254	0,087	600	8000	2500	55,79	G56467	63-90
0,687	2.546	0,077	600	8000	2500	55,79	G56468	63-80
0,613	2.856	0,069	600	8000	2500	55,79	G56469	63-80
0,532	3.288	0,060	600	8000	2500	55,79	G56470	63-71
0,494	3.544	0,056	600	8000	2500	55,79	G56471	63-71
0,450	3.888	0,051	600	8000	2500	55,79	G56472	63-71

0,389	4.503	0,045	600	8000	2500	54,63	G56573	63-100
0,365	4.795	0,042	600	8000	2500	54,63	G56574	63-100
0,305	5.733	0,035	600	8000	2500	54,63	G56575	63-100
0,270	6.470	0,031	600	8000	2500	54,63	G56576	63-100
0,250	6.993	0,029	600	8000	2500	54,63	G56577	63-100
0,228	7.672	0,026	600	8000	2500	54,63	G56578	63-100
0,197	8.861	0,023	600	8000	2500	54,63	G56579	63-90
0,174	10.085	0,020	600	8000	2500	54,63	G56580	63-80
0,154	11.357	0,018	600	8000	2500	54,63	G56581	63-80
0,133	13.163	0,015	600	8000	2500	54,63	G56582	63-71
0,123	14.236	0,014	600	8000	2500	54,63	G56583	63-71
0,111	15.718	0,013	600	8000	2500	54,63	G56584	63-71



690 - 1550 Nm

58

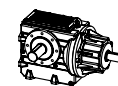

229	7,63	24,4	840	4000	2200	82,74	G58218	80-180
190	9,21	24,3	1010	4200	2200	82,74	G58219	80-180
173	10,1	24,1	1100	4300	2200	82,74	G58220	80-180
155	11,3	24,3	1240	4500	2200	82,74	G58221	80-160
141	12,4	24,2	1300	4900	2200	82,74	G58222	80-160
122	14,3	20,1	1300	5300	2200	82,74	G58223	80-160

\* Verificar limites motor / redutor na página 77



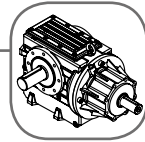

690 - 1550 Nm

58

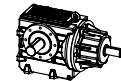

rpm	i <sub>tot</sub>	kW	Mt (Nm)	Fr (N)	rpm.máx	η%	código	carcaça*
107	16,4	17,0	1300	5400	2200	82,74	G58224	80-132
90,7	19,3	13,8	1300	5500	2200	82,74	G58226	80-132
81,8	21,4	15,5	1300	5900	2200	71,91	G58227	80-132
65,1	26,9	12,3	1300	6500	2200	71,91	G58229	80-180
57,8	30,3	10,9	1300	6700	2200	71,91	G58230	80-160
52,7	33,2	10,0	1300	7500	2200	71,91	G58231	80-160
45,7	38,3	8,6	1300	9000	2200	71,91	G58232	80-160
40,0	43,8	7,56	1300	9000	2200	71,91	G58233	80-132
34,0	51,5	6,43	1300	9000	2200	71,91	G58234	80-132
30,5	57,3	5,78	1300	9000	2200	71,91	G58235	80-132
26,0	67,4	4,92	1300	9000	2200	71,91	G58236	80-100
24,3	71,9	4,61	1300	9000	2200	71,91	G58237	80-100
22,4	78,2	5,24	1300	9000	2200	58,12	G58238	80-160
20,4	85,7	4,78	1300	9000	2200	58,12	G58239	80-160
17,7	98,9	4,14	1300	9000	2200	58,12	G58240	80-160
15,5	113	3,63	1300	9000	2200	58,12	G58241	80-132
13,2	133	3,08	1300	9000	2200	58,12	G58243	80-132
11,8	148	2,77	1300	9000	2200	58,12	G58244	80-132
9,41	186	2,20	1300	9000	2200	58,12	G58245	80-100
8,45	207	1,98	1300	9000	2200	58,12	G58246	80-90
7,74	226	2,89	1300	9000	2200	36,45	G58247	80-132
6,58	266	2,46	1300	9000	2200	36,45	G58248	80-132
5,91	296	2,21	1300	9000	2200	36,45	G58250	80-132
5,03	348	1,88	1300	9000	2200	36,45	G58251	80-100
4,23	414	1,58	1300	9000	2200	36,45	G58252	80-90
3,80	461	1,42	1300	9000	2200	36,45	G58253	80
3,38	518	1,26	1300	9000	2200	36,45	G58254	80



1550 Nm

58

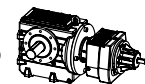

3,15	555	0,769	1300	9000	2200	55,79	G58455	63-132
2,83	618	0,691	1300	9000	2200	55,79	G58456	63-132
2,54	689	0,620	1300	9000	2200	55,79	G58457	63-132
2,35	745	0,573	1300	9000	2200	55,79	G58458	63-132
1,94	901	0,474	1300	9000	2200	55,79	G58459	63-132
1,69	1.034	0,413	1300	9000	2200	55,79	G58460	63-132
1,52	1.154	0,370	1300	9000	2200	55,79	G58461	63-132
1,40	1.248	0,342	1300	9000	2200	55,79	G58462	63-132
1,29	1.355	0,315	1300	9000	2200	55,79	G58463	63-132
1,16	1.508	0,283	1300	9000	2200	55,79	G58464	63-132

\* Verificar limites motor / redutor na página 77



1550 Nm

58

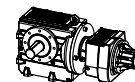

rpm	$i_{tot}$	<b>kW</b>	Mt (Nm)	Fr (N)	rpm.máx	$\eta\%$	código	carcaça*
1,00	1.744	0,245	1300	9000	2200	55,79	G58465	63-132
0,848	2.063	0,207	1300	9000	2200	55,79	G58466	63-132
0,756	2.314	0,185	1300	9000	2200	55,79	G58467	63-132
0,638	2.743	0,156	1300	9000	2200	55,79	G58468	63-100
0,594	2.947	0,145	1300	9000	2200	55,79	G58469	63-100
0,529	3.311	0,129	1300	9000	2200	55,79	G58470	63-90
0,536	3.267	0,133	1300	9000	2200	54,63	G58571	63-132
0,437	4.007	0,109	1300	9000	2200	54,63	G58572	63-132
0,383	4.573	0,095	1300	9000	2200	54,63	G58573	63-132
0,334	5.247	0,083	1300	9000	2200	54,63	G58574	63-112
0,311	5.635	0,077	1300	9000	2200	54,63	G58575	63-100
0,276	6.331	0,069	1300	9000	2200	54,63	G58576	63-132
0,251	6.977	0,062	1300	9000	2200	54,63	G58577	63-132
0,225	7.766	0,056	1300	9000	2200	54,63	G58578	63-132
0,197	8.864	0,049	1300	9000	2200	54,63	G58579	63-132
0,172	10.170	0,043	1300	9000	2200	54,63	G58580	63-112
0,160	10.921	0,040	1300	9000	2200	54,63	G58581	63-100
0,148	11.844	0,037	1300	9000	2200	54,63	G58582	63-100
0,130	13.506	0,032	1300	9000	2200	54,63	G58583	63-90
0,115	15.255	0,029	1300	9000	2200	54,63	G58584	63-80
0,102	17.116	0,025	1300	9000	2200	54,63	G58585	63-80
0,089	19.701	0,022	1300	9000	2200	54,63	G58586	63-71
0,082	21.236	0,021	1300	9000	2200	54,63	G58587	63-71
0,075	23.299	0,019	1300	9000	2200	54,63	G58588	63-71

\* Verificar limites motor / redutor na página 77

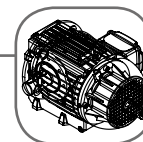

Weg normal / Tipo 1

4 pólos					6 pólos					8 pólos				
Carc.	CV	kW	RPM	Cód.	Carc.	CV	kW	RPM	Cód.	Carc.	CV	kW	RPM	Cód.
63	0,16	0,12	1720	B_W	63	0,16	0,12	1130	B_W	71	0,16	0,12	805	C_W
63	0,25	0,18	1710	B_W	71	0,25	0,18	1090	C_W	80	0,25	0,18	865	D_W
63	0,33	0,25	1710	B_W	71	0,33	0,25	1100	C_W	80	0,33	0,25	860	D_W
71	0,5	0,37	1720	C_W	80	0,50	0,37	1150	D_W	90S	0,50	0,37	850	E_W
71	0,75	0,55	1705	C_W	80	0,75	0,55	1150	D_W	90L	0,75	0,55	830	F_W
80	1	0,75	1720	D_W	90S	1,0	0,75	1130	E_W	90L	1,0	0,75	820	F_W
80	1,5	1,1	1720	D_W	90S	1,5	1,1	1130	E_W	100L	1,5	1,1	860	G_W
90S	2	1,5	1740	E_W	100L	2,0	1,5	1150	G_W	112M	2,0	1,5	855	H_W
90L	3	2,2	1730	F_W	100L	3,0	2,2	1140	G_W	132S	3,0	2,2	860	J_W
100L	4	3	1725	G_W	112M	4,0	3,0	1145	H_W	132M	4,0	3,0	865	K_W
100L	5	3,7	1715	G_W	132S	5,0	3,7	1160	J_W	132M	5,0	3,7	865	K_W
112M	6	4,5	1720	H_W	132S	6,0	4,5	1160	J_W	132M	5,0	3,7	865	K_W
112M	7,5	5,5	1740	H_W	132M	7,5	5,5	1160	K_W	160M	6,0	4,5	875	L_W
132S	10	7,5	1760	J_W	132M	10	7,5	1160	K_W	160M	7,5	5,5	875	L_W
132M	12,5	9,2	1755	K_W	160M	12,5	9,2	1160	L_W	160L	10	7,5	875	M_W
132M	15	11	1755	K_W	160M	15	11	1170	L_W	180M	12,5	9,2	875	N_W
160M	20	15	1760	L_W	160L	20	15	1170	M_W	180L	15	11	875	P_W
160L	25	18,5	1760	M_W	180L	25	18,5	1165	P_W	180L	20	15	870	P_W
180M	30	22	1765	N_W	200L	30	22	1175	R_W	200L	25	18,5	880	R_W
200M	40	30	1770	Q_W	200L	40	30	1175	R_W	225S/M	30	22	880	S_W
200L	50	37	1770	R_W	225S/M	50	37	1180	S_W	225S/M	40	30	880	S_W
225S/M	60	45	1775	S_W	—	—	—	—	—	—	—	—	—	—
225S/M	75	55	1770	S_W	—	—	—	—	—	—	—	—	—	—

Características padrão

- 60 Hz
- Classe de Isolação "F", "H"
- Caixa de ligação A1
- Grau de Proteção IPW 55
- Motores Weg até 0,75 - 220/380V, acima 4 tensões
- Flange FF (Forma B5E)
- Motores Eberle - 4 tensões

Opcionais (sob consulta) inclusive motor tipo 1

- Frequência de 50 Hz e 50/60Hz
- Classe de Isolação "F", "H"
- Calota de Proteção\*
- Ventilação Forçada
- Proteção Térmica
- 2ª Ponta de Eixo
- Tensões (V) de 220, 380, 440, 480, 220/380, 380/660, 440/660, 460, 110/220 (monofásico), 220/380/440/760 (4 tensões)
- Freio de 220 V, 380 V, 440 V, 110 V 1F, 24 VDC
- Grau de Proteção IPW 55 ou IP 56
- Placa de Bornes
- Massa Adicion. Inércia
- Resistência Aquecimento
- Faixa do Protetor
- Polaridade do Motor de 2, 2/4, 2/6, 4/6, 4/8, 6/8, 2/8 pólos
- Motores especiais dedicados a aplicações especiais

\*Calota de Proteção recomendada para motorreduztores na posição de trabalho P4



# Fixação por pés - N

## Simple

**Dimensões**  
Tamanho **51**

Tipos de Entrada

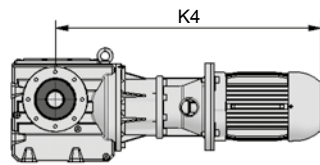

Flange Lanterna com Motor

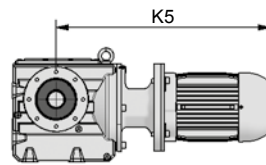

Flange KTR com Motor

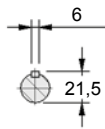

Eixo de Entrada

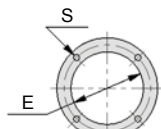

Detalhes Flange Lanterna

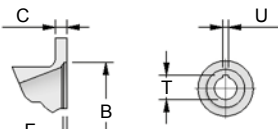

Detalhe "x"

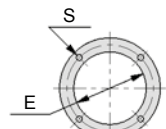

Detalhes Flange KTR

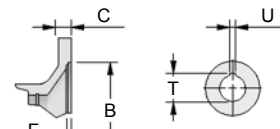

Detalhe "y"

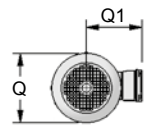

Frente do Motor

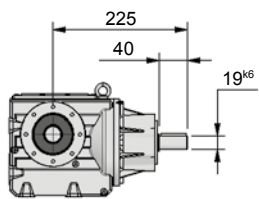

Mancal

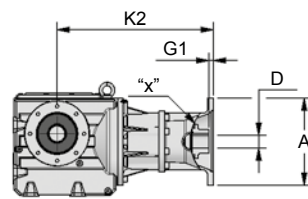

Flange Lanterna

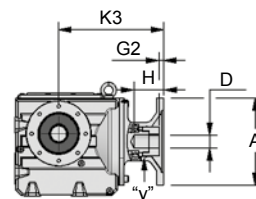

Flange KTR

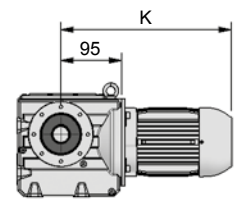

Motor

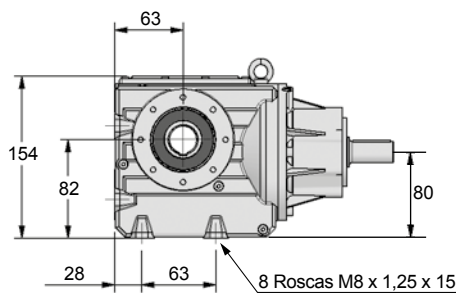

Eixo Integral Simple

Eixo Integral Duplo

Eixo Vazado com Chaveta

Eixo Vazado com Disco de Contração

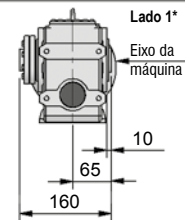
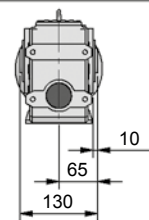
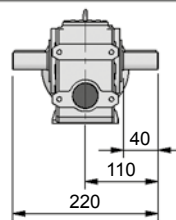
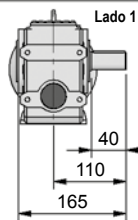

Sugestão de acoplamento no Eixo Vazado

Sugestão de acoplamento no Eixo Vazado com Disco de Contração

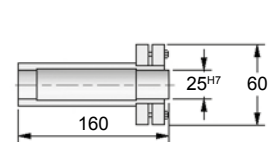
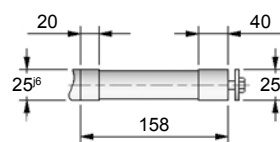
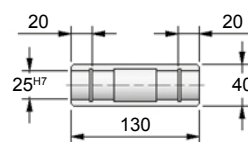
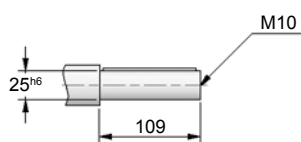

Tipos de Saída

Carcaça	Flange Lanterna / KTR														Motor Elétrico				
	A	B	C	D	E	F	G1	G2	H	K2	K3	S	T	U	K	K4	K5	Q	Q1
63	140	95 <sup>H7</sup>	13	ø11	115	4	0	1	25	259	179,5	10	12,8	4	335	452	372,5	124	113
71	160	110 <sup>H7</sup>	14	ø14	130	4	0,5	1	34	260	179,5	10	16,3	5	367	478	397,5	139	121
80	200	130 <sup>H7</sup>	15	ø19	165	4	10	1	44	277	218	12	21,8	6	394	513	454	157	130
90S	200	130 <sup>H7</sup>	15	ø24	165	4	10	1	52	277	218	12	27,3	8	416	531	472	177	150
90L	200	130 <sup>H7</sup>	15	ø24	165	4	10	1	52	277	218	12	27,3	8	441	556	497	177	150
100	250	180 <sup>H7</sup>	16	ø28	215	5	20	—	—	289	—	15	31,3	8	493	605	—	198	160
112	250	180 <sup>H7</sup>	16	ø28	215	5	20	—	—	289	—	15	31,3	8	—	622	—	235	180

\* Lado 2: inverter as posições do disco e entrada do eixo da máquina

# Dimensões

Tamanho **51**

## Fixação por flange e pés - G A / G C

Simplex



Tipos de Entrada

Tipos de Saída

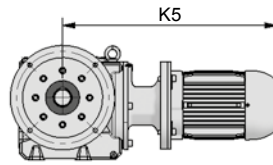
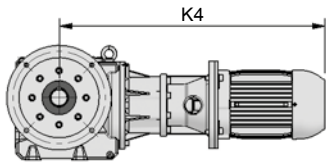

Flange Lanterna com Motor

Flange KTR com Motor

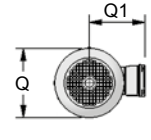
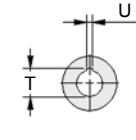
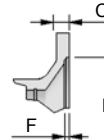
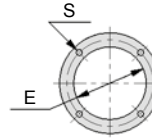
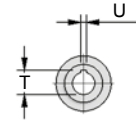
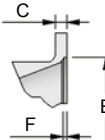
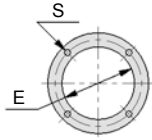
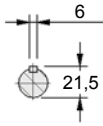

Eixo de Entrada

Detalhes Flange Lanterna

Detalhe "x"

Detalhes Flange KTR

Detalhe "y"

Frente do Motor

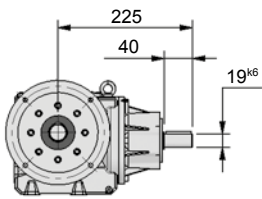

Mancal

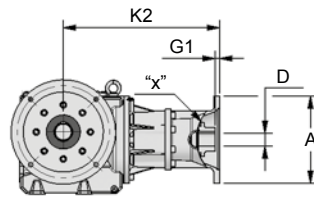

Flange Lanterna

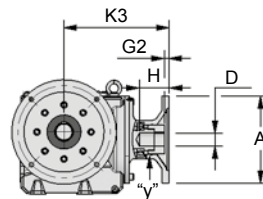

Flange KTR

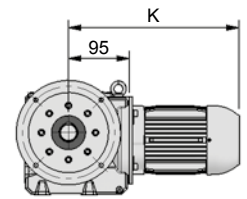

Motor

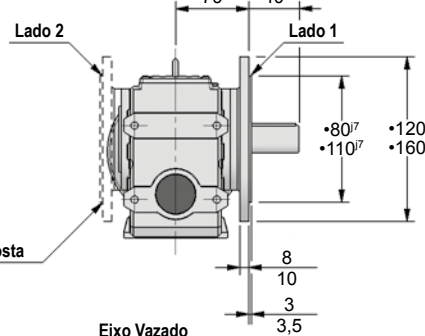
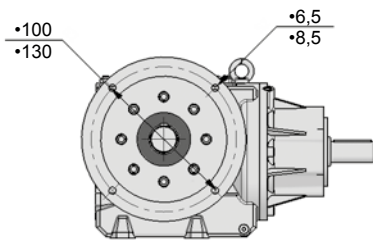

Opção Flange Oposta

Eixo Integral Simplex

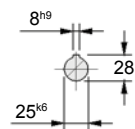
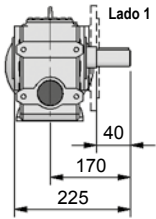

Eixo Integral Duplo

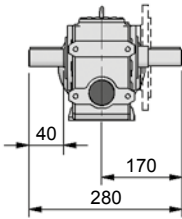

Eixo Vazado com Chaveta

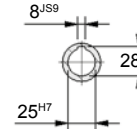
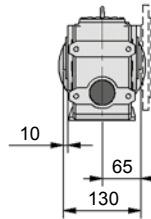

Eixo Vazado com Disco de Contração

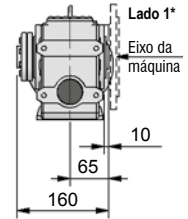

Sugestão de acoplamento no Eixo Vazado

Sugestão de acoplamento no Eixo Vazado com Disco de Contração

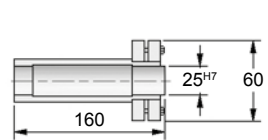
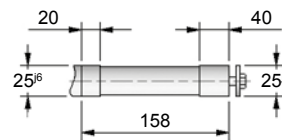
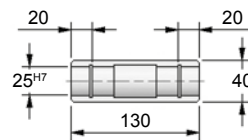
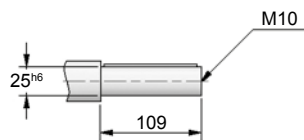

Carcaça	Flange Lanterna / KTR										Motor Elétrico								
	A	B	C	D	E	F	G1	G2	H	K2	K3	S	T	U	K	K4	K5	Q	Q1
63	140	95 <sup>H7</sup>	13	ø11	115	4	0	1	25	259	179,5	10	12,8	4	335	452	372,5	124	113
71	160	110 <sup>H7</sup>	14	ø14	130	4	0,5	1	34	260	179,5	10	16,3	5	367	478	397,5	139	121
80	200	130 <sup>H7</sup>	15	ø19	165	4	10	1	44	277	218	12	21,8	6	394	513	454	157	130
90S	200	130 <sup>H7</sup>	15	ø24	165	4	10	1	52	277	218	12	27,3	8	416	531	472	177	150
90L	200	130 <sup>H7</sup>	15	ø24	165	4	10	1	52	277	218	12	27,3	8	441	556	497	177	150
100	250	180 <sup>H7</sup>	16	ø28	215	5	20	—	—	289	—	15	31,3	8	493	605	—	198	160
112	250	180 <sup>H7</sup>	16	ø28	215	5	20	—	—	289	—	15	31,3	8	—	622	—	235	180

\* Lado 2: inverter as posições do disco e entrada do eixo da máquina - •Disponível em em dois tamanhos de flange: ØA = 120mm (dimensões indicadas no flange superior) - ØC = 160mm (dimensões indicadas no flange inferior)



# Fixação por braço de torção - B

## Simple

Dimensões

Tamanho **51**

Tipos de Entrada

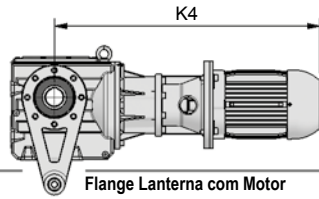

Flange Lanterna com Motor

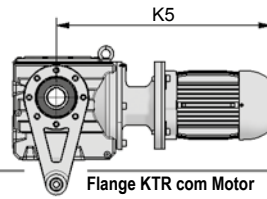

Flange KTR com Motor

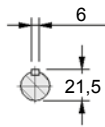

Eixo de Entrada

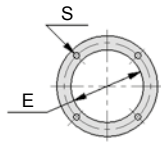

Detalhes Flange Lanterna

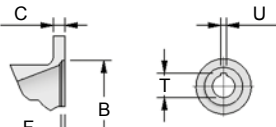

Detalhe "x"

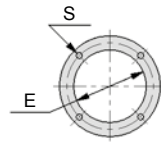

Detalhes Flange KTR

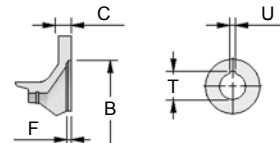

Detalhe "y"

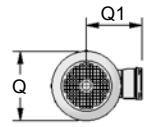

Frente do Motor

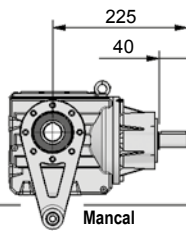

Mancal

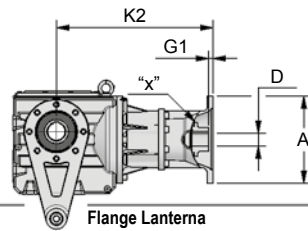

Flange Lanterna

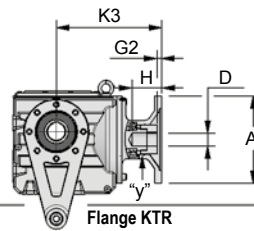

Flange KTR

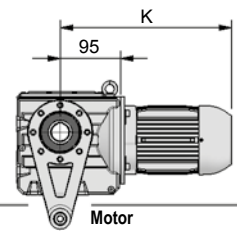

Motor

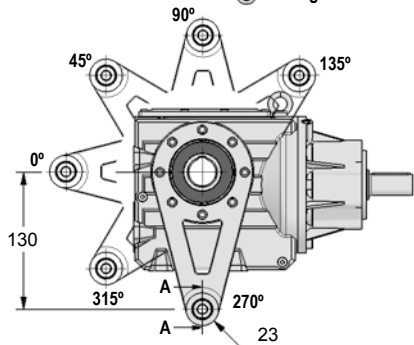

Eixo Vazado com Chaveta

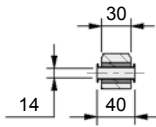

Corte "AA"

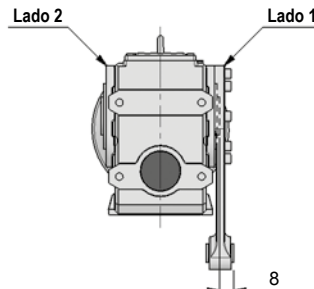

Eixo Vazado com Disco de Contração

Tipos de Saída

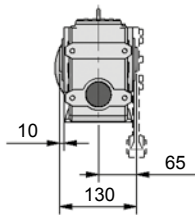

Sugestão de acoplamento no Eixo Vazado

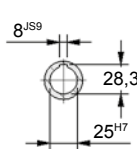

Sugestão de acoplamento no Eixo Vazado com Disco de Contração

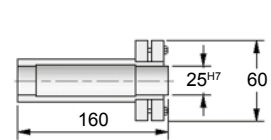
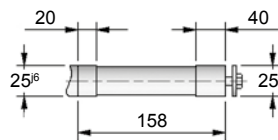
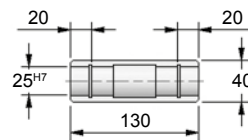
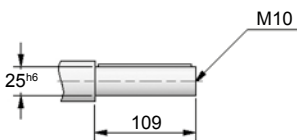
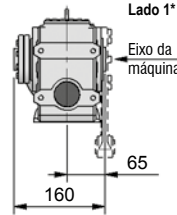

Carcaça	Flange Lanterna / KTR														Motor Elétrico				
	A	B	C	D	E	F	G1	G2	H	K2	K3	S	T	U	K	K4	K5	Q	Q1
63	140	95 <sup>H7</sup>	13	∅11	115	4	0	1	25	259	179,5	10	12,8	4	335	452	372,5	124	113
71	160	110 <sup>H7</sup>	14	∅14	130	4	0,5	1	34	260	179,5	10	16,3	5	367	478	397,5	139	121
80	200	130 <sup>H7</sup>	15	∅19	165	4	10	1	44	277	218	12	21,8	6	394	513	454	157	130
90S	200	130 <sup>H7</sup>	15	∅24	165	4	10	1	52	277	218	12	27,3	8	416	531	472	177	150
90L	200	130 <sup>H7</sup>	15	∅24	165	4	10	1	52	277	218	12	27,3	8	441	556	497	177	150
100	250	180 <sup>H7</sup>	16	∅28	215	5	20	—	—	289	—	15	31,3	8	493	605	—	198	160
112	250	180 <sup>H7</sup>	16	∅28	215	5	20	—	—	289	—	15	31,3	8	—	622	—	235	180

\* Lado 2: inverter as posições do disco e entrada do eixo da máquina

# Dimensões

Tamanho **52**

# Fixação por pés - N Simples

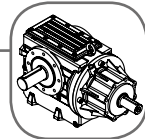

Tipos de Entrada

Tipos de Saída

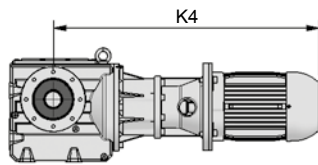

Flange Lanterna com Motor

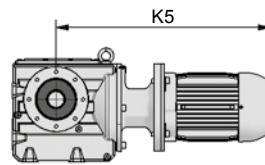

Flange KTR com Motor

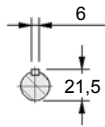

Eixo de Entrada

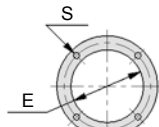

Detalhes Flange Lanterna

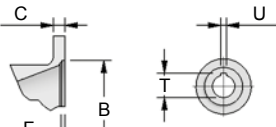

Detalhe "x"

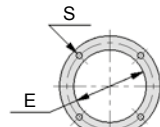

Detalhes Flange KTR

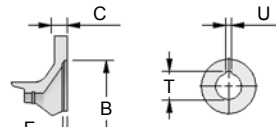

Detalhe "y"

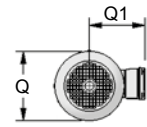

Frente do Motor

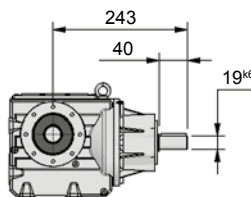

Mancal

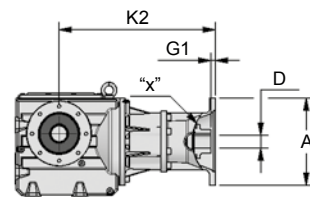

Flange Lanterna

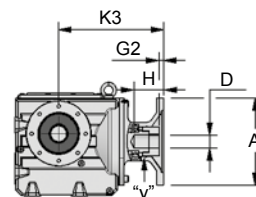

Flange KTR

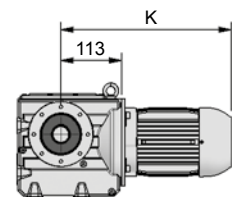

Motor

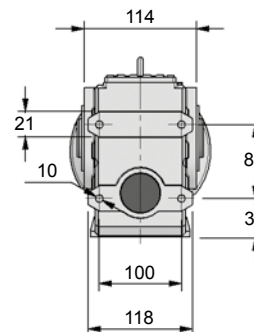
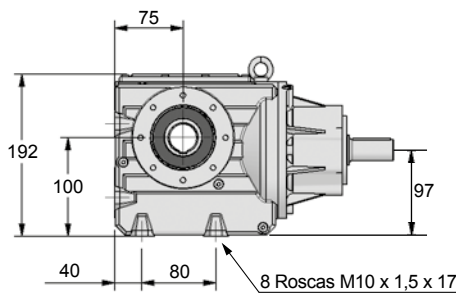

Eixo Integral Simples

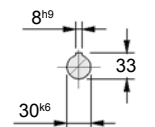
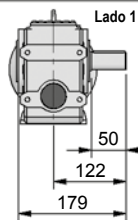

Eixo Integral Duplo

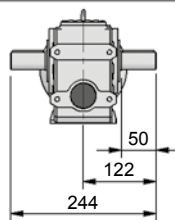

Eixo Vazado com Chaveta

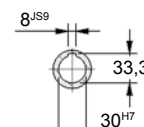
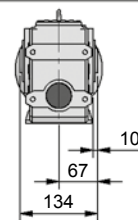

Eixo Vazado com Disco de Contração

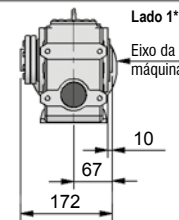

Eixo da máquina

Sugestão de acoplamento no Eixo Vazado

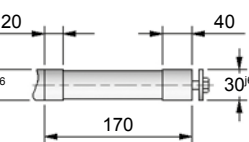
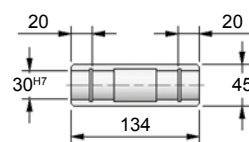
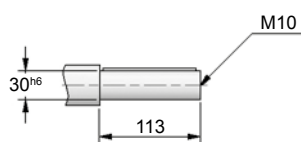

Sugestão de acoplamento no Eixo Vazado com Disco de Contração

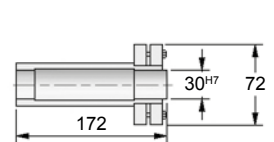

Flange Lanterna / KTR

Motor Elétrico

Carcaça	A	B	C	D	E	F	G1	G2	H	K2	K3	S	T	U	K	K4	K5	Q	Q1
63	140	95 <sup>H7</sup>	13	∅11	115	4	0	1	25	277	197,5	10	12,8	4	353	470	390,5	124	113
71	160	110 <sup>H7</sup>	14	∅14	130	4	0,5	1	34	278	197,5	10	16,3	5	385	496	415,5	139	121
80	200	130 <sup>H7</sup>	15	∅19	165	4	10	1	44	295	236	12	21,8	6	412	531	472	157	130
90S	200	130 <sup>H7</sup>	15	∅24	165	4	10	1	52	295	236	12	27,3	8	434	549	490	177	150
90L	200	130 <sup>H7</sup>	15	∅24	165	4	10	1	52	295	236	12	27,3	8	459	574	515	177	150
100	250	180 <sup>H7</sup>	16	∅28	215	5	20	—	—	307	—	15	31,3	8	511	623	—	198	160
112	250	180 <sup>H7</sup>	16	∅28	215	5	20	—	—	307	—	15	31,3	8	—	640	—	235	180

\* Lado 2: inverter as posições do disco e entrada do eixo da máquina



# Fixação por flange e pés - G C

## Simple

Dimensões

Tamanho **52**

Tipos de Entrada

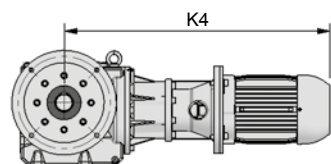

Flange Lanterna com Motor

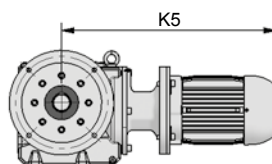

Flange KTR com Motor

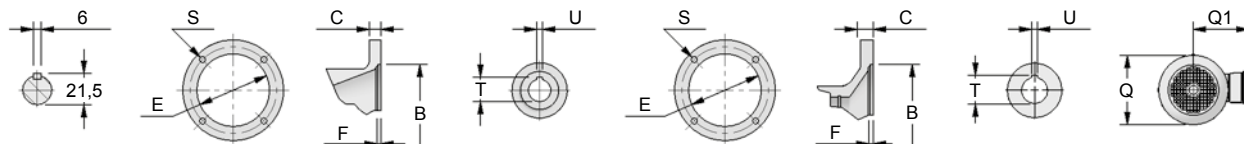

Eixo de Entrada

Detalhes Flange Lanterna

Detalhe "x"

Detalhes Flange KTR

Detalhe "y"

Frente do Motor

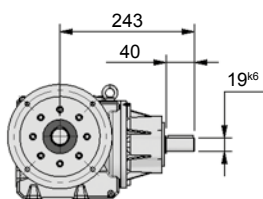

Mancal

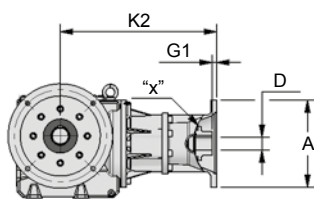

Flange Lanterna

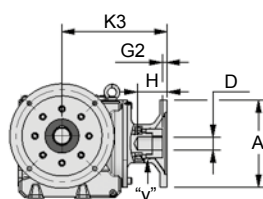

Flange KTR

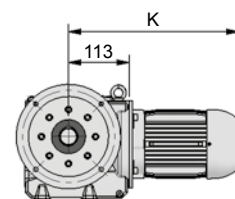

Motor

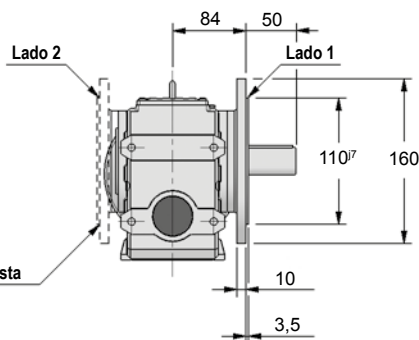
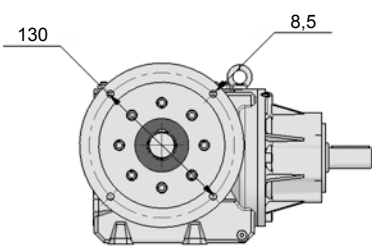

Eixo Integral Simple

Eixo Integral Duplo

Eixo Vazado com Chaveta

Eixo Vazado com Disco de Contração

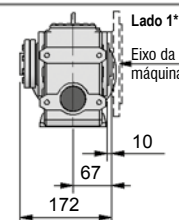
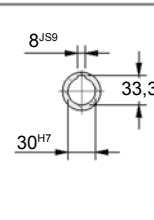
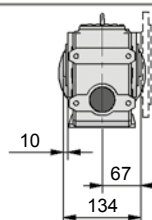
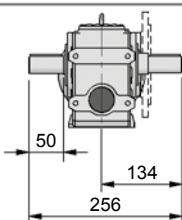
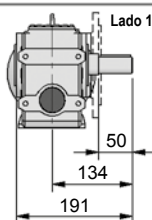

Sugestão de acoplamento no Eixo Vazado

Sugestão de acoplamento no Eixo Vazado com Disco de Contração

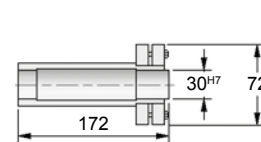
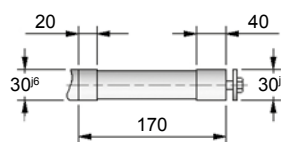
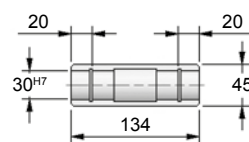
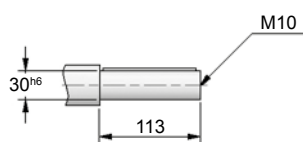

Tipos de Saída

Carcaca	Flange Lanterna / KTR									Motor Elétrico									
	A	B	C	D	E	F	G1	G2	H	K2	K3	S	T	U	K	K4	K5	Q	Q1
63	140	95 <sup>H7</sup>	13	∅11	115	4	0	1	25	277	197,5	10	12,8	4	353	470	390,5	124	113
71	160	110 <sup>H7</sup>	14	∅14	130	4	0,5	1	34	278	197,5	10	16,3	5	385	496	415,5	139	121
80	200	130 <sup>H7</sup>	15	∅19	165	4	10	1	44	295	236	12	21,8	6	412	531	472	157	130
90S	200	130 <sup>H7</sup>	15	∅24	165	4	10	1	52	295	236	12	27,3	8	434	549	490	177	150
90L	200	130 <sup>H7</sup>	15	∅24	165	4	10	1	52	295	236	12	27,3	8	459	574	515	177	150
100	250	180 <sup>H7</sup>	16	∅28	215	5	20	—	—	307	—	15	31,3	8	511	623	—	198	160
112	250	180 <sup>H7</sup>	16	∅28	215	5	20	—	—	307	—	15	31,3	8	—	640	—	235	180

\* Lado 2: inverter as posições do disco e entrada do eixo da máquina



# Dimensões

Tamanho **52**

## Fixação por braço de torção - B

Simple

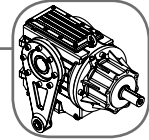

Tipos de Entrada

Tipos de Saída

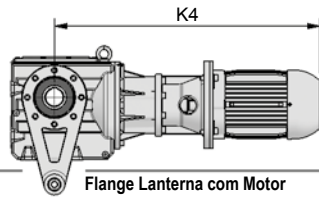

Flange Lanterna com Motor

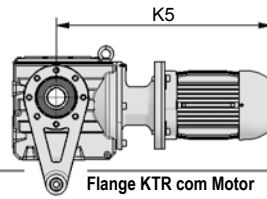

Flange KTR com Motor

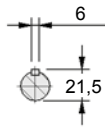

Eixo de Entrada

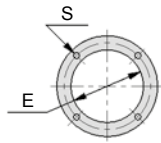

Detalhes Flange Lanterna

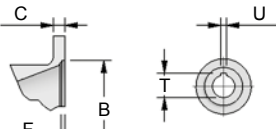

Detalhe "x"

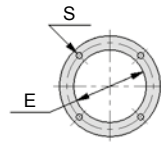

Detalhes Flange KTR

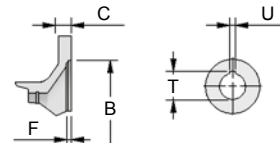

Detalhe "y"

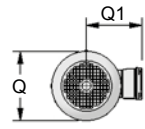

Frente do Motor

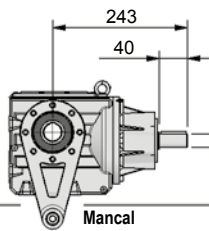

Mancal

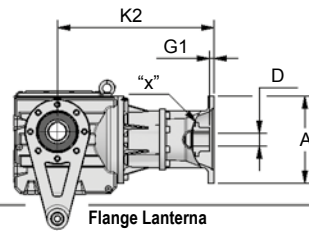

Flange Lanterna

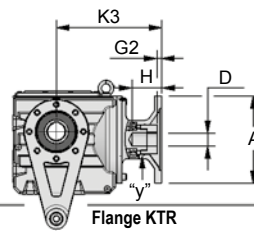

Flange KTR

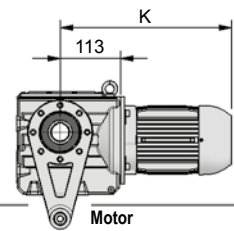

Motor

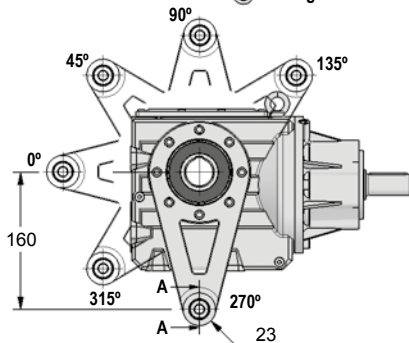

Eixo Vazado com Chaveta

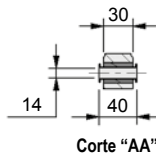

Corte "AA"

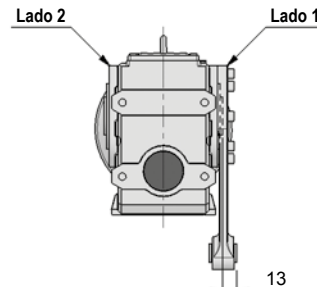

Eixo Vazado com Disco de Contração

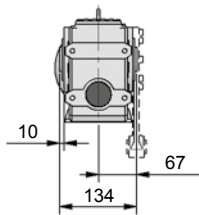

Sugestão de acoplamento no Eixo Vazado

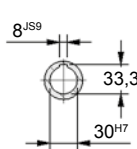

Sugestão de acoplamento no Eixo Vazado com Disco de Contração

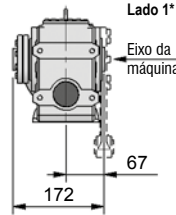

14

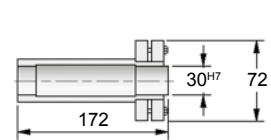
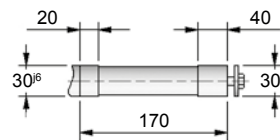
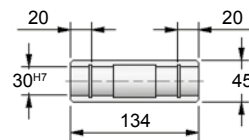
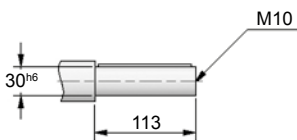

Carcaça	Flange Lanterna / KTR										Motor Elétrico								
	A	B	C	D	E	F	G1	G2	H	K2	K3	S	T	U	K	K4	K5	Q	Q1
63	140	95 <sup>H7</sup>	13	∅11	115	4	0	1	25	277	197,5	10	12,8	4	353	470	390,5	124	113
71	160	110 <sup>H7</sup>	14	∅14	130	4	0,5	1	34	278	197,5	10	16,3	5	385	496	415,5	139	121
80	200	130 <sup>H7</sup>	15	∅19	165	4	10	1	44	295	236	12	21,8	6	412	531	472	157	130
90S	200	130 <sup>H7</sup>	15	∅24	165	4	10	1	52	295	236	12	27,3	8	434	549	490	177	150
90L	200	130 <sup>H7</sup>	15	∅24	165	4	10	1	52	295	236	12	27,3	8	459	574	515	177	150
100	250	180 <sup>H7</sup>	16	∅28	215	5	20	—	—	307	—	15	31,3	8	511	623	—	198	160
112	250	180 <sup>H7</sup>	16	∅28	215	5	20	—	—	307	—	15	31,3	8	—	640	—	235	180

\* Lado 2: inverter as posições do disco e entrada do eixo da máquina



# Fixação por pés - N

## Simple

**Dimensões**  
Tamanho **54**

Tipos de Entrada



Flange Lanterna com Motor

Flange KTR com Motor

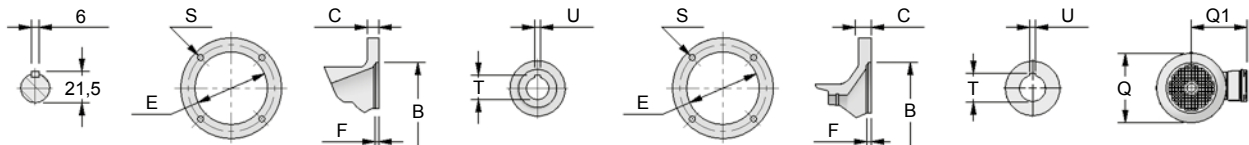

Eixo de Entrada

Detalhes Flange Lanterna

Detalhe "x"

Detalhes Flange KTR

Detalhe "y"

Frente do Motor

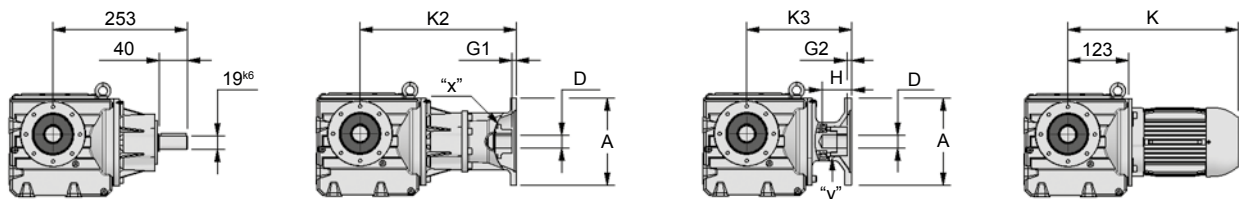

Mancal

Flange Lanterna

Flange KTR

Motor

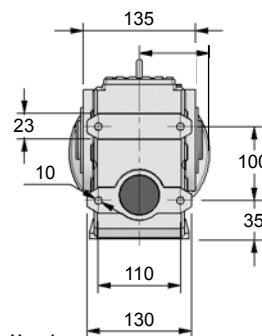
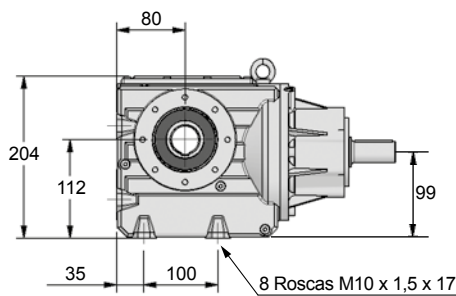

Eixo Integral Simple

Eixo Integral Duplo

Eixo Vazado com Chaveta

Eixo Vazado com Disco de Contração

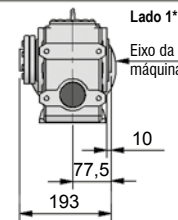
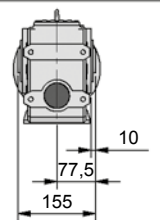
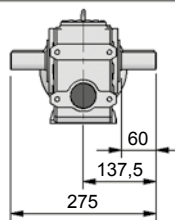
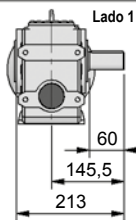

Sugestão de acoplamento no Eixo Vazado

Sugestão de acoplamento no Eixo Vazado com Disco de Contração

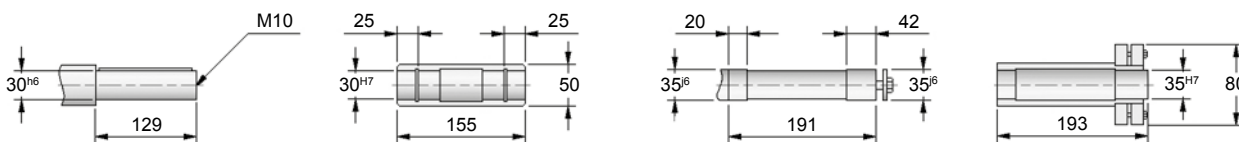

Carcaça	Flange Lanterna / KTR														Motor Elétrico				
	A	B	C	D	E	F	G1	G2	H	K2	K3	S	T	U	K	K4	K5	Q	Q1
63	140	95 <sup>H7</sup>	13	∅11	115	4	0	1	25	287	201	10	12,8	4	356,5	480	394	124	113
71	160	110 <sup>H7</sup>	14	∅14	130	4	0,5	1	34	288	201	10	16,3	5	388,5	506	419	139	121
80	200	130 <sup>H7</sup>	15	∅19	165	4	10	1	44	305	239,5	12	21,8	6	415,5	541	475,5	157	130
90S	200	130 <sup>H7</sup>	15	∅24	165	4	10	1	52	305	239,5	12	27,3	8	437,5	559	493,5	177	150
90L	200	130 <sup>H7</sup>	15	∅24	165	4	10	1	52	305	239,5	12	27,3	8	462,5	584	518,5	177	150
100	250	180 <sup>H7</sup>	16	∅28	215	5	20	1	63	317	262	15	31,3	8	512	633	578	198	160
112	250	180 <sup>H7</sup>	16	∅28	215	5	20	1	63	317	262	15	31,3	8	529	650	595	235	180
132S	—	—	—	—	—	—	—	—	—	—	—	—	—	—	615	—	—	274	207
132M	—	—	—	—	—	—	—	—	—	—	—	—	—	—	653	—	—	274	207

\* Lado 2: inverter as posições do disco e entrada do eixo da máquina

# Dimensões

Tamanho **54**

## Fixação por flange e pés - G. D

Simplex

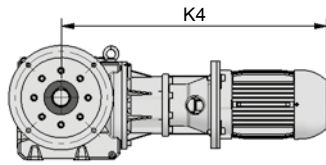
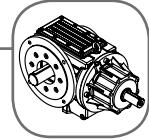

Flange Lanterna com Motor

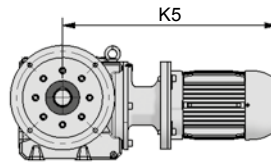

Flange KTR com Motor

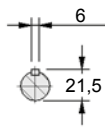

Eixo de Entrada

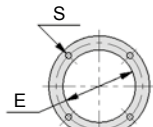

Detalhes Flange Lanterna

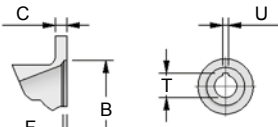

Detalhe "x"

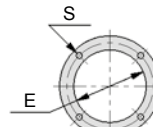

Detalhes Flange KTR

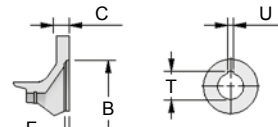

Detalhe "y"

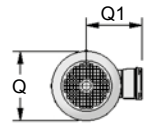

Frente do Motor

Tipos de Entrada

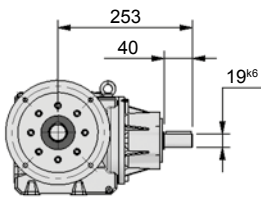

Mancal

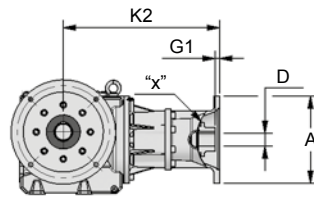

Flange Lanterna

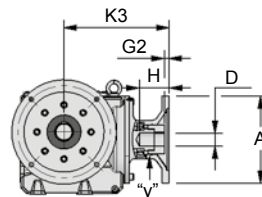

Flange KTR

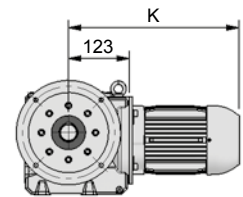

Motor

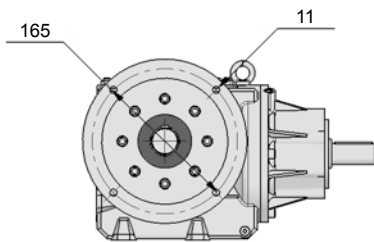

Opção Flange Oposta

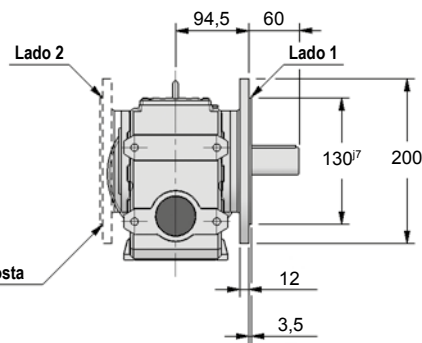

Eixo Integral Simplex

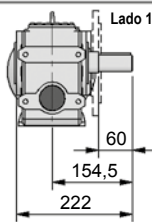

Eixo Integral Duplo

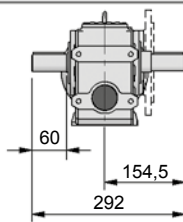

Eixo Vazado com Chaveta

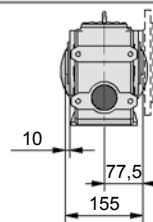

Eixo Vazado com Disco de Contração

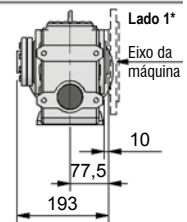

Tipos de Saída

Sugestão de acoplamento no Eixo Vazado

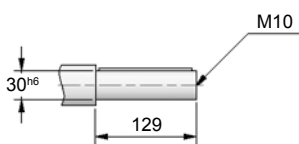

Sugestão de acoplamento no Eixo Vazado com Disco de Contração

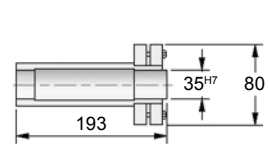
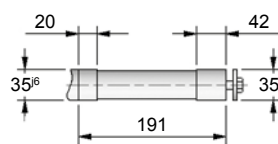
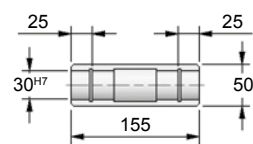

14

Carcaça	Flange Lanterna / KTR										Motor Elétrico								
	A	B	C	D	E	F	G1	G2	H	K2	K3	S	T	U	K	K4	K5	Q	Q1
63	140	95 <sup>H7</sup>	13	ø11	115	4	0	1	25	287	201	10	12,8	4	356,5	480	394	124	113
71	160	110 <sup>H7</sup>	14	ø14	130	4	0,5	1	34	288	201	10	16,3	5	388,5	506	419	139	121
80	200	130 <sup>H7</sup>	15	ø19	165	4	10	1	44	305	239,5	12	21,8	6	415,5	541	475,5	157	130
90S	200	130 <sup>H7</sup>	15	ø24	165	4	10	1	52	305	239,5	12	27,3	8	437,5	559	493,5	177	150
90L	200	130 <sup>H7</sup>	15	ø24	165	4	10	1	52	305	239,5	12	27,3	8	462,5	584	518,5	177	150
100	250	180 <sup>H7</sup>	16	ø28	215	5	20	1	63	317	262	15	31,3	8	512	633	578	198	160
112	250	180 <sup>H7</sup>	16	ø28	215	5	20	1	63	317	262	15	31,3	8	529	650	595	235	180
132S	—	—	—	—	—	—	—	—	—	—	—	—	—	—	615	—	—	274	207
132M	—	—	—	—	—	—	—	—	—	—	—	—	—	—	653	—	—	274	207

\* Lado 2: inverter as posições do disco e entrada do eixo da máquina



# Fixação por braço de torção - B

## Simple

Dimensões

Tamanho **54**

Tipos de Entrada

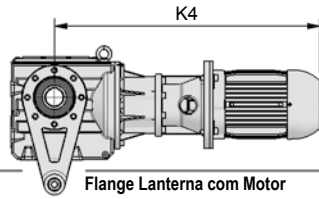

Flange Lanterna com Motor

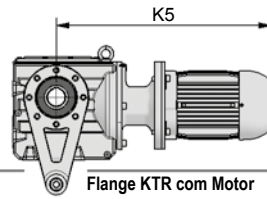

Flange KTR com Motor

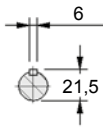

Eixo de Entrada

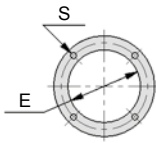

Detalhes Flange Lanterna

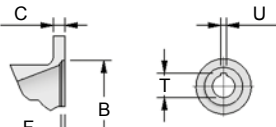

Detalhe "x"

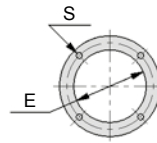

Detalhes Flange KTR

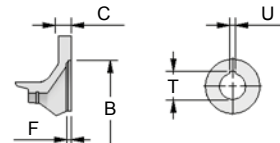

Detalhe "y"

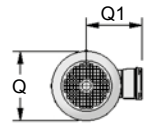

Frente do Motor

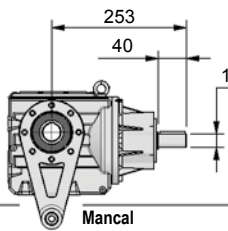

Mancal

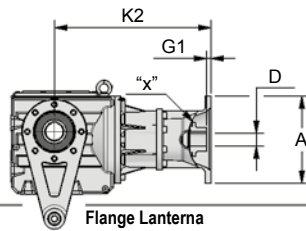

Flange Lanterna

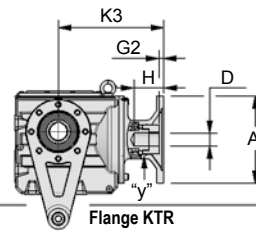

Flange KTR

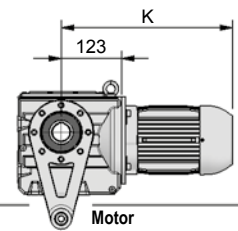

Motor

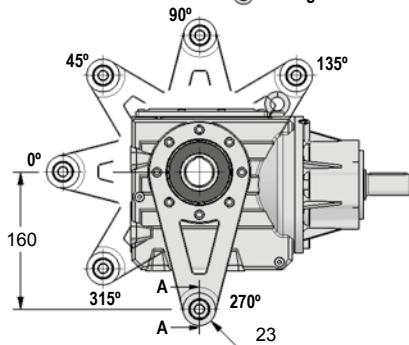

Eixo Vazado com Chaveta

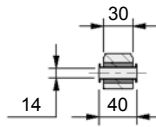

Corte "AA"

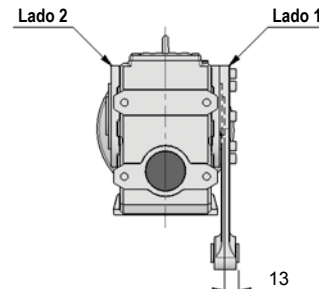

Eixo Vazado com Disco de Contração

Tipos de Saída

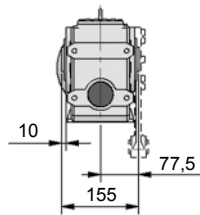

Sugestão de acoplamento no Eixo Vazado

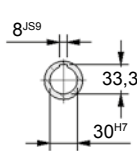

Sugestão de acoplamento no Eixo Vazado com Disco de Contração

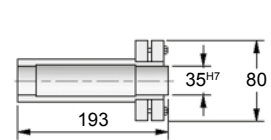
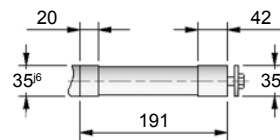
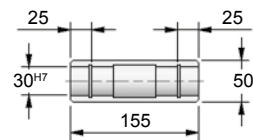
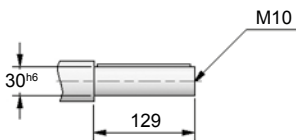
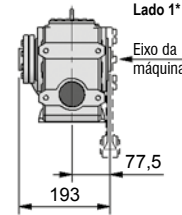

Carcaça	Flange Lanterna / KTR										Motor Elétrico								
	A	B	C	D	E	F	G1	G2	H	K2	K3	S	T	U	K	K4	K5	Q	Q1
63	140	95 <sup>H7</sup>	13	∅11	115	4	0	1	25	287	201	10	12,8	4	356,5	480	394	124	113
71	160	110 <sup>H7</sup>	14	∅14	130	4	0,5	1	34	288	201	10	16,3	5	388,5	506	419	139	121
80	200	130 <sup>H7</sup>	15	∅19	165	4	10	1	44	305	239,5	12	21,8	6	415,5	541	475,5	157	130
90S	200	130 <sup>H7</sup>	15	∅24	165	4	10	1	52	305	239,5	12	27,3	8	437,5	559	493,5	177	150
90L	200	130 <sup>H7</sup>	15	∅24	165	4	10	1	52	305	239,5	12	27,3	8	462,5	584	518,5	177	150
100	250	180 <sup>H7</sup>	16	∅28	215	5	20	1	63	317	262	15	31,3	8	512	633	578	198	160
112	250	180 <sup>H7</sup>	16	∅28	215	5	20	1	63	317	262	15	31,3	8	529	650	595	235	180
132S	—	—	—	—	—	—	—	—	—	—	—	—	—	—	615	—	—	274	207
132M	—	—	—	—	—	—	—	—	—	—	—	—	—	—	653	—	—	274	207

\* Lado 2: inverter as posições do disco e entrada do eixo da máquina

# Dimensões

Tamanho **56**

## Fixação por pés - N

Simplex

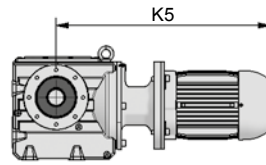
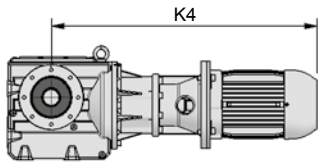

Flange Lanterna com Motor

Flange KTR com Motor

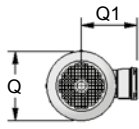
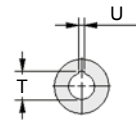
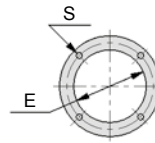
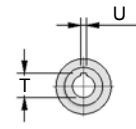
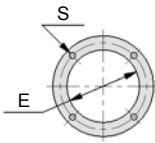
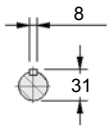

Tipos de Entrada

Eixo de Entrada

Detalhes Flange Lanterna

Detalhe "x"

Detalhes Flange KTR

Detalhe "y"

Frente do Motor

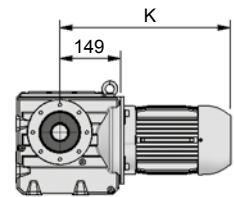
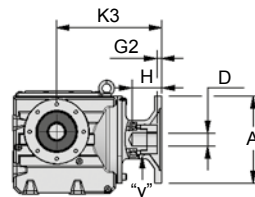
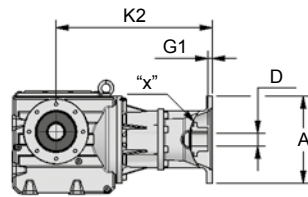
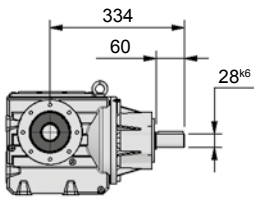

Mancal

Flange Lanterna

Flange KTR

Motor

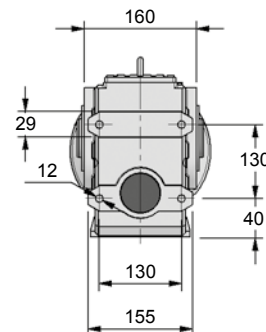
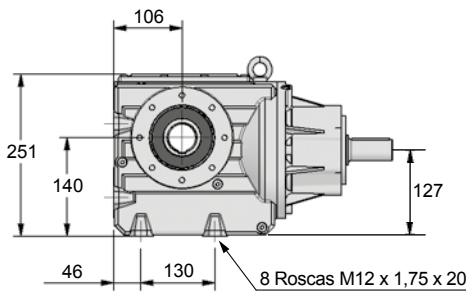

Eixo Integral Simplex

Eixo Integral Duplo

Eixo Vazado com Chaveta

Eixo Vazado com Disco de Contração

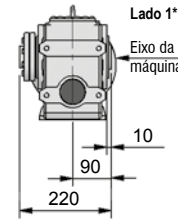
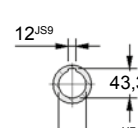
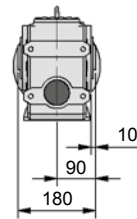
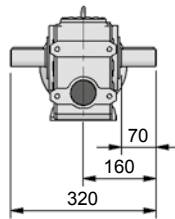
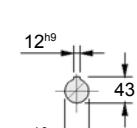
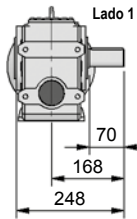

Tipos de Saída

Sugestão de acoplamento no Eixo Vazado

Sugestão de acoplamento no Eixo Vazado com Disco de Contração

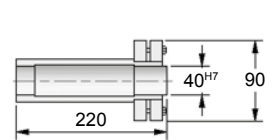
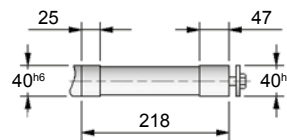
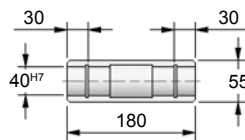
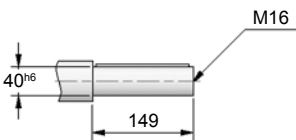

14

Carcaça	Flange Lanterna / KTR										Motor Elétrico								
	A	B	C	D	E	F	G1	G2	H	K2	K3	S	T	U	K	K4	K5	Q	Q1
63	140	95 <sup>H7</sup>	13	∅11	115	4	0	—	—	374	—	10	12,8	4	376,5	567	—	124	113
71	160	110 <sup>H7</sup>	14	∅14	130	4	0,5	1	34	374	221	10	16,3	5	408,5	592	439	139	121
80	200	130 <sup>H7</sup>	15	∅19	165	4	10	1	44	387	259,5	12	21,8	6	435,5	623	495,5	157	130
90S	200	130 <sup>H7</sup>	15	∅24	165	4	10	1	52	387	259,5	12	27,3	8	455,5	641	513,5	177	150
90L	200	130 <sup>H7</sup>	15	∅24	165	4	10	1	52	387	259,5	12	27,3	8	480,5	666	538,5	177	150
100	250	180 <sup>H7</sup>	16	∅28	215	5	20	1	63	397	280	15	31,3	8	530	713	596	198	160
112	250	180 <sup>H7</sup>	16	∅28	215	5	20	1	63	397	280	15	31,3	8	546	730	613	235	180
132S	300	230 <sup>H7</sup>	17	∅38	265	5	30	1	83	417	335	15	41,3	10	629	789	707	274	207
132M	300	230 <sup>H7</sup>	17	∅38	265	5	30	1	83	417	335	15	41,3	10	667	827	745	274	207
160M	—	—	—	—	—	—	—	—	—	—	—	—	—	—	680	—	—	317	250
160L	—	—	—	—	—	—	—	—	—	—	—	—	—	—	724	—	—	317	250

\* Lado 2: inverter as posições do disco e entrada do eixo da máquina



# Fixação por flange e pés - G D

## Simple

Dimensões

Tamanho **56**

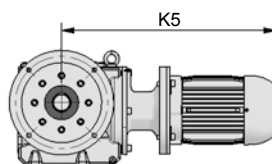
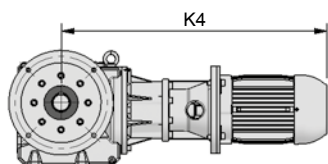

Flange Lanterna com Motor

Flange KTR com Motor

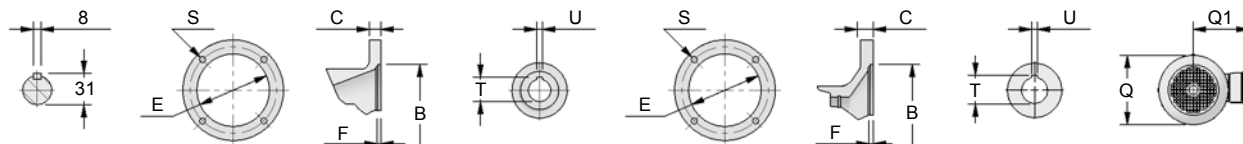

Eixo de Entrada

Detalhes Flange Lanterna

Detalhe "x"

Detalhes Flange KTR

Detalhe "y"

Frente do Motor

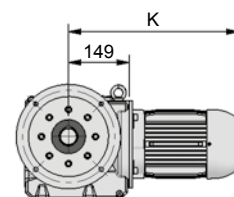
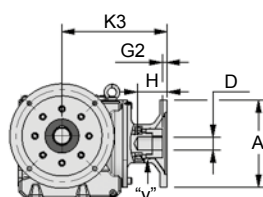
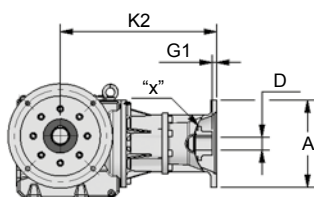
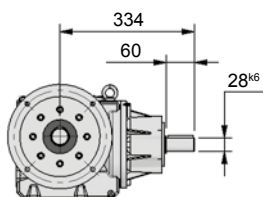

Mancal

Flange Lanterna

Flange KTR

Motor

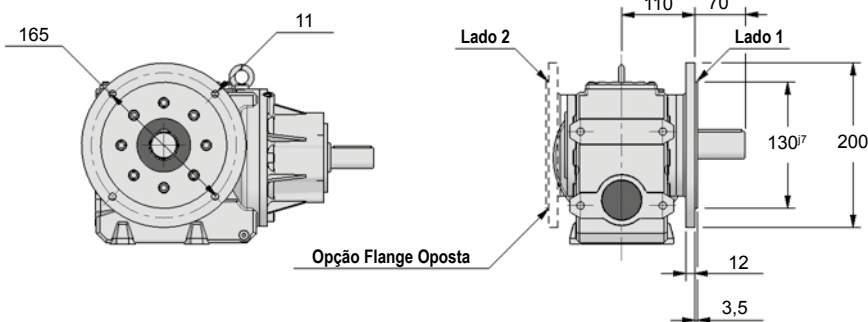

Opção Flange Oposta

Eixo Integral Simple

Eixo Integral Duplo

Eixo Vazado com Chaveta

Eixo Vazado com Disco de Contração

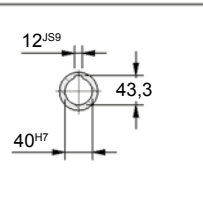
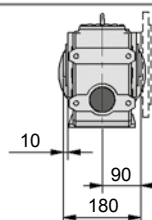
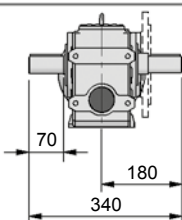
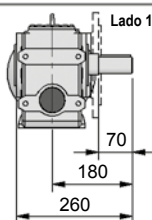

Sugestão de acoplamento no Eixo Vazado

Sugestão de acoplamento no Eixo Vazado com Disco de Contração

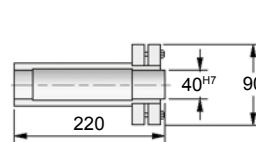
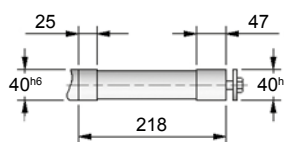
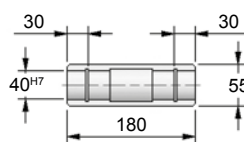
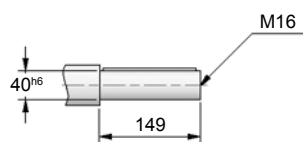

Carcaça	Flange Lanterna / KTR										Motor Elétrico								
	A	B	C	D	E	F	G1	G2	H	K2	K3	S	T	U	K	K4	K5	Q	Q1
63	140	95 <sup>H7</sup>	13	ø11	115	4	0	—	—	374	—	10	12,8	4	376,5	567	—	124	113
71	160	110 <sup>H7</sup>	14	ø14	130	4	0,5	1	34	374	221	10	16,3	5	408,5	592	439	139	121
80	200	130 <sup>H7</sup>	15	ø19	165	4	10	1	44	387	259,5	12	21,8	6	435,5	623	495,5	157	130
90S	200	130 <sup>H7</sup>	15	ø24	165	4	10	1	52	387	259,5	12	27,3	8	455,5	641	513,5	177	150
90L	200	130 <sup>H7</sup>	15	ø24	165	4	10	1	52	387	259,5	12	27,3	8	480,5	666	538,5	177	150
100	250	180 <sup>H7</sup>	16	ø28	215	5	20	1	63	397	280	15	31,3	8	530	713	596	198	160
112	250	180 <sup>H7</sup>	16	ø28	215	5	20	1	63	397	280	15	31,3	8	546	730	613	235	180
132S	300	230 <sup>H7</sup>	17	ø38	265	5	30	1	83	417	335	15	41,3	10	629	789	707	274	207
132M	300	230 <sup>H7</sup>	17	ø38	265	5	30	1	83	417	335	15	41,3	10	667	827	745	274	207
160M	—	—	—	—	—	—	—	—	—	—	—	—	—	—	680	—	—	317	250
160L	—	—	—	—	—	—	—	—	—	—	—	—	—	—	724	—	—	317	250

\* Lado 2: inverter as posições do disco e entrada do eixo da máquina

# Dimensões

Tamanho **56**

## Fixação por braço de torção - B

Simple



Tipos de Entrada

Tipos de Saída

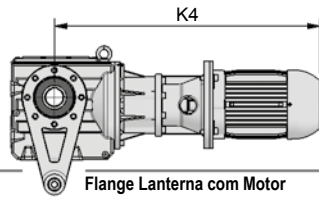

Flange Lanterna com Motor

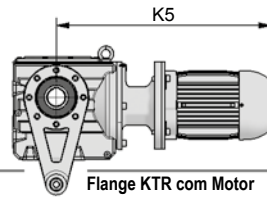

Flange KTR com Motor

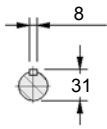

Eixo de Entrada

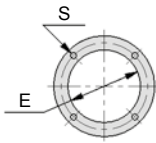

Detalhes Flange Lanterna

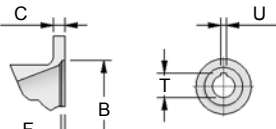

Detalhe "x"

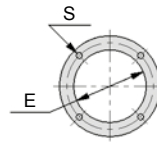

Detalhes Flange KTR

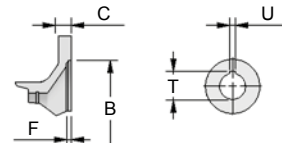

Detalhe "y"

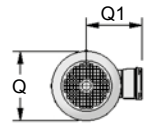

Frente do Motor

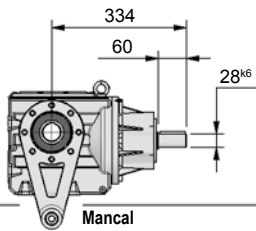

Mancal

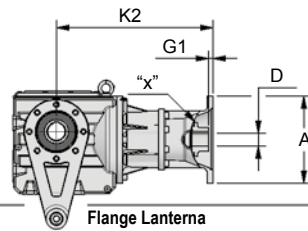

Flange Lanterna

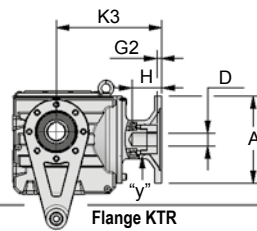

Flange KTR

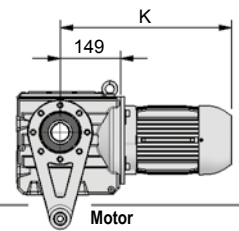

Motor

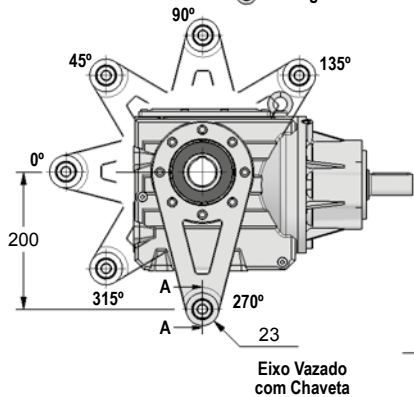

Eixo Vazado com Chaveta

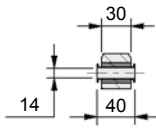

Corte "AA"

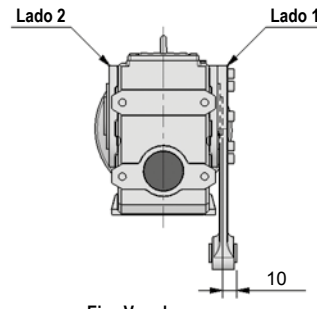

Eixo Vazado com Disco de Contração

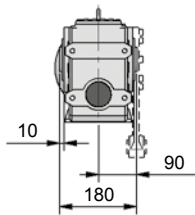

Sugestão de acoplamento no Eixo Vazado

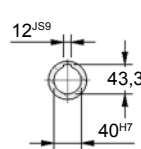

Sugestão de acoplamento no Eixo Vazado com Disco de Contração

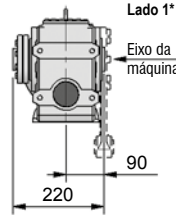

Lado 1\*

Eixo da máquina

14

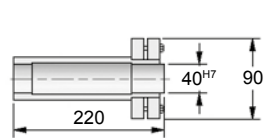
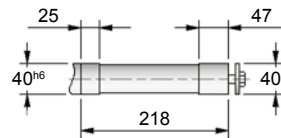
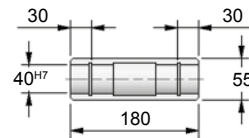
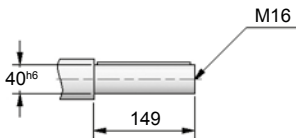

Carcaça	Flange Lanterna / KTR											Motor Elétrico							
	A	B	C	D	E	F	G1	G2	H	K2	K3	S	T	U	K	K4	K5	Q	Q1
63	140	95 <sup>H7</sup>	13	∅11	115	4	0	—	—	374	—	10	12,8	4	376,5	567	—	124	113
71	160	110 <sup>H7</sup>	14	∅14	130	4	0,5	1	34	374	221	10	16,3	5	408,5	592	439	139	121
80	200	130 <sup>H7</sup>	15	∅19	165	4	10	1	44	387	259,5	12	21,8	6	435,5	623	495,5	157	130
90S	200	130 <sup>H7</sup>	15	∅24	165	4	10	1	52	387	259,5	12	27,3	8	455,5	641	513,5	177	150
90L	200	130 <sup>H7</sup>	15	∅24	165	4	10	1	52	387	259,5	12	27,3	8	480,5	666	538,5	177	150
100	250	180 <sup>H7</sup>	16	∅28	215	5	20	1	63	397	280	15	31,3	8	530	713	596	198	160
112	250	180 <sup>H7</sup>	16	∅28	215	5	20	1	63	397	280	15	31,3	8	546	730	613	235	180
132S	300	230 <sup>H7</sup>	17	∅38	265	5	30	1	83	417	335	15	41,3	10	629	789	707	274	207
132M	300	230 <sup>H7</sup>	17	∅38	265	5	30	1	83	417	335	15	41,3	10	667	827	745	274	207
160M	—	—	—	—	—	—	—	—	—	—	—	—	—	—	680	—	—	317	250
160L	—	—	—	—	—	—	—	—	—	—	—	—	—	—	724	—	—	317	250

\* Lado 2: inverter as posições do disco e entrada do eixo da máquina



# Fixação por pés - N

## Simple

**Dimensões**  
Tamanho **58**

Tipos de Entrada



Flange Lanterna com Motor

Flange KTR com Motor

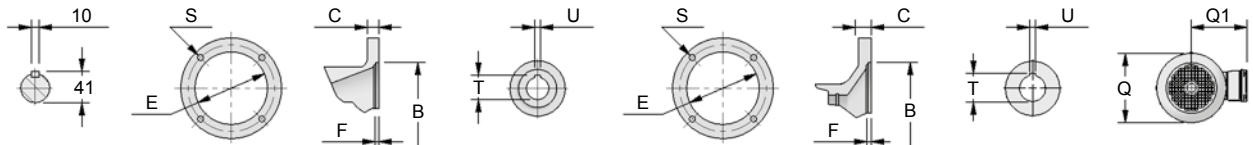

Eixo de Entrada

Detalhes Flange Lanterna

Detalhe "x"

Detalhes Flange KTR

Detalhe "y"

Frente do Motor

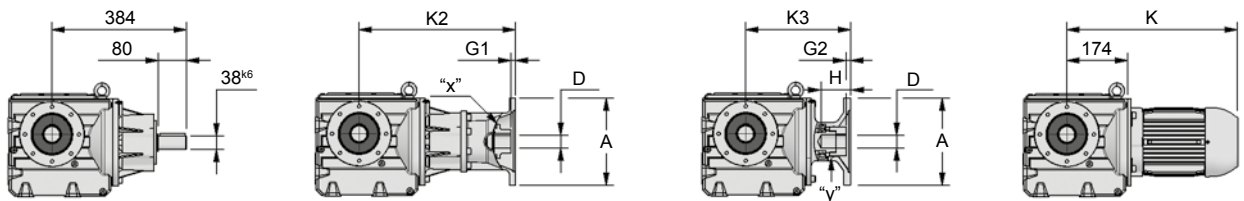

Mancais

Flange Lanterna

Flange KTR

Motor

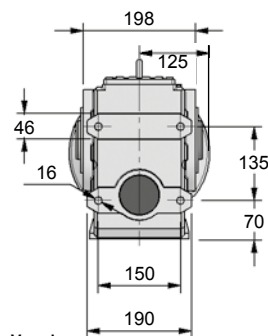
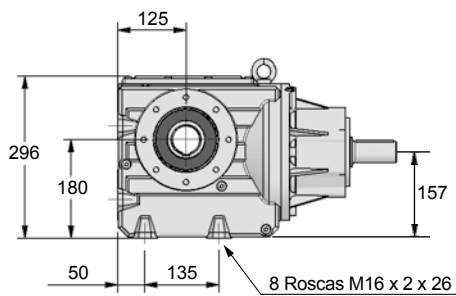

Eixo Integral Simples

Eixo Integral Duplo

Eixo Vazado com Chaveta

Eixo Vazado com Disco de Contração

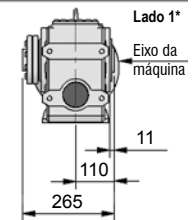
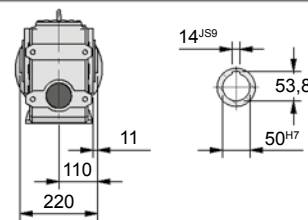
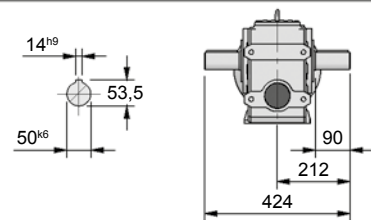
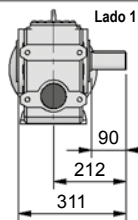

Sugestão de acoplamento no Eixo Vazado

Sugestão de acoplamento no Eixo Vazado com Disco de Contração

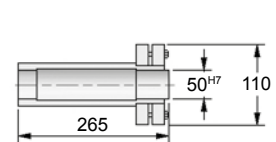
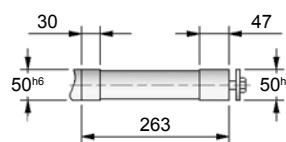
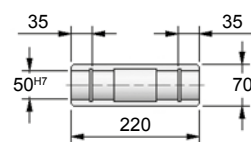
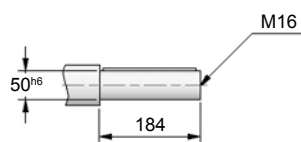

Carcaça	Flange Lanterna / KTR										Motor Elétrico								
	A	B	C	D	E	F	G1	G2	H	K2	K3	S	T	U	K	K4	K5	Q	Q1
80	200	130 <sup>H7</sup>	15	∅19	165	4	10	1	44	438	279	12	21,8	6	455,5	674	515	157	130
90S	200	130 <sup>H7</sup>	15	∅24	165	4	10	1	52	438	279	12	27,3	8	476,5	692	533	177	150
90L	200	130 <sup>H7</sup>	15	∅24	165	4	10	1	52	438	279	12	27,3	8	501,5	717	558	177	150
100	250	180 <sup>H7</sup>	16	∅28	215	5	20	1	63	447	302,5	15	31,3	8	551	763	618,5	198	160
112	250	180 <sup>H7</sup>	16	∅28	215	5	20	1	63	447	302,5	15	31,3	8	566	780	635,5	235	180
132S	300	230 <sup>H7</sup>	17	∅38	265	5	30	1	83	467	355	15	41,3	10	649	839	727	274	207
132M	300	230 <sup>H7</sup>	17	∅38	265	5	30	1	83	467	355	15	41,3	10	687	877	765	274	207
160M	350	250 <sup>H7</sup>	24	∅42	300	6	40	1	112	499	403	19	45,3	12	700	987	891	317	250
160L	350	250 <sup>H7</sup>	24	∅42	300	6	40	1	112	499	403	19	45,3	12	744	1031	935	317	250
180M	350	250 <sup>H7</sup>	24	∅48	300	6	40	1	113	499	403	19	51,8	14	774	1053	957	360	270

\* Lado 2: inverter as posições do disco e entrada do eixo da máquina



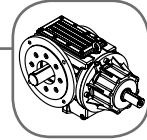

Tipos de Entrada

Tipos de Saída

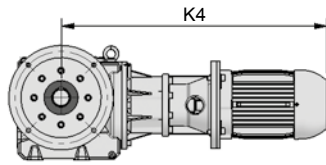

Flange Lanterna com Motor

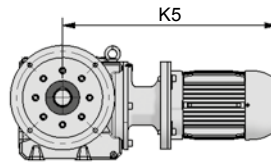

Flange KTR com Motor

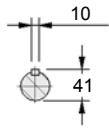

Eixo de Entrada

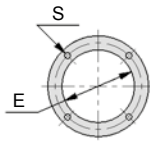

Detalhes Flange Lanterna

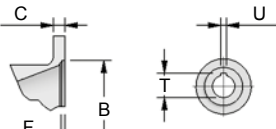

Detalhe "x"

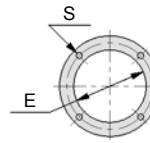

Detalhes Flange KTR

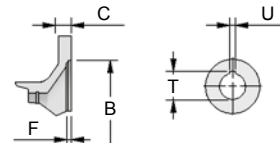

Detalhe "y"

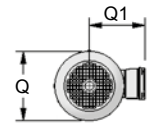

Frente do Motor

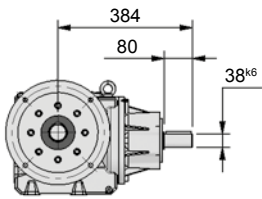

Mancal

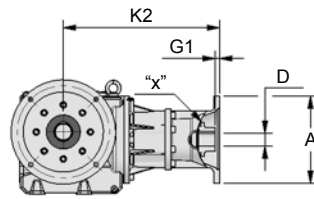

Flange Lanterna

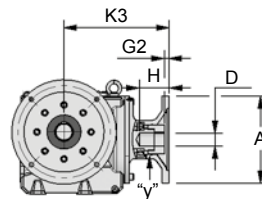

Flange KTR

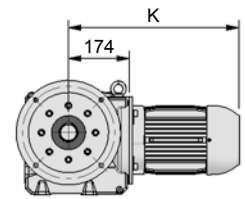

Motor

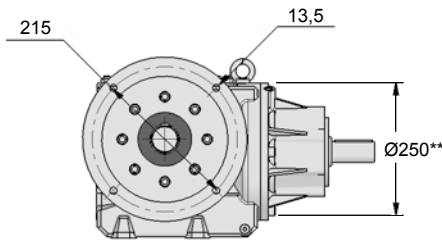

Opção Flange Oposta

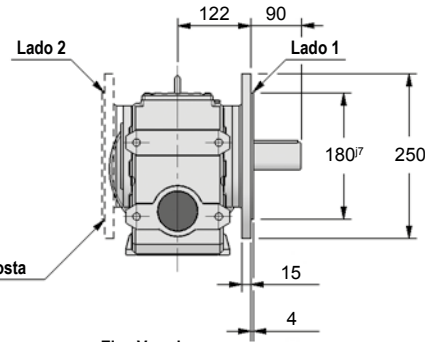

Eixo Integral Simplex

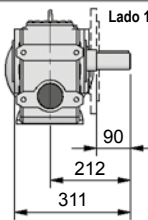

Eixo Integral Duplo

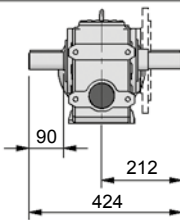

Eixo Vazado com Chaveta

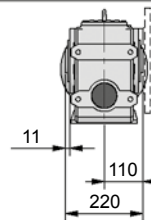

Eixo Vazado com Disco de Contração

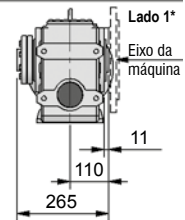

Sugestão de acoplamento no Eixo Vazado

Sugestão de acoplamento no Eixo Vazado com Disco de Contração

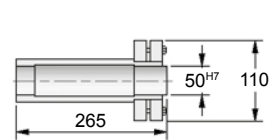
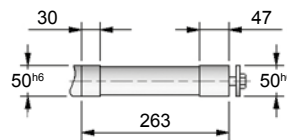
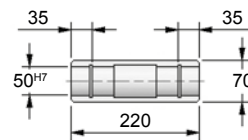
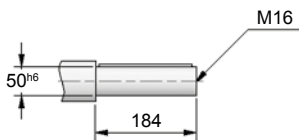

Carcaça	Flange Lanterna / KTR										Motor Elétrico								
	A	B	C	D	E	F	G1	G2	H	K2	K3	S	T	U	K	K4	K5	Q	Q1
80	200	130 <sup>H7</sup>	15	∅19	165	4	10	1	44	438	279	12	21,8	6	455,5	674	515	157	130
90S	200	130 <sup>H7</sup>	15	∅24	165	4	10	1	52	438	279	12	27,3	8	476,5	692	533	177	150
90L	200	130 <sup>H7</sup>	15	∅24	165	4	10	1	52	438	279	12	27,3	8	501,5	717	558	177	150
100	250	180 <sup>H7</sup>	16	∅28	215	5	20	1	63	447	302,5	15	31,3	8	551	763	618,5	198	160
112	250	180 <sup>H7</sup>	16	∅28	215	5	20	1	63	447	302,5	15	31,3	8	566	780	635,5	235	180
132S	300	230 <sup>H7</sup>	17	∅38	265	5	30	1	83	467	355	15	41,3	10	649	839	727	274	207
132M	300	230 <sup>H7</sup>	17	∅38	265	5	30	1	83	467	355	15	41,3	10	687	877	765	274	207
160M	350	250 <sup>H7</sup>	24	∅42	300	6	40	1	112	499	403	19	45,3	12	700	987	891	317	250
160L	350	250 <sup>H7</sup>	24	∅42	300	6	40	1	112	499	403	19	45,3	12	744	1031	935	317	250
180M	350	250 <sup>H7</sup>	24	∅48	300	6	40	1	113	499	403	19	51,8	14	774	1053	957	360	270

\* Lado 2: inverter as posições do disco e entrada do eixo da máquina

\*\* Face entrada do redutor tem dimensão Ø250



# Fixação por braço de torção - B

## Simple

Dimensões

Tamanho **58**

Tipos de Entrada

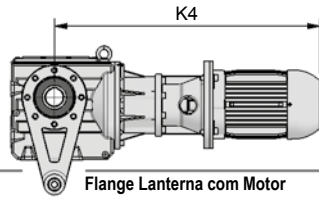

Flange Lanterna com Motor

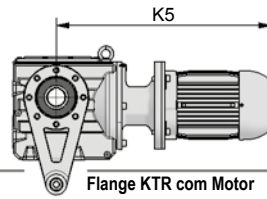

Flange KTR com Motor

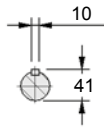

Eixo de Entrada

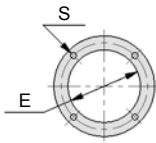

Detalhes Flange Lanterna

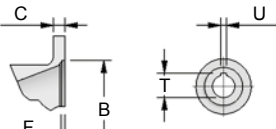

Detalhe "x"

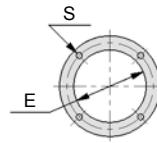

Detalhes Flange KTR

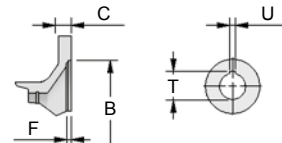

Detalhe "y"

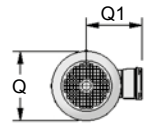

Frente do Motor

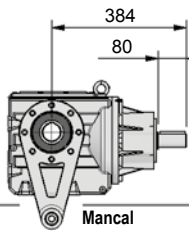

Mancal

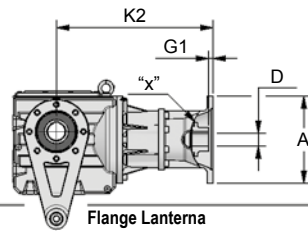

Flange Lanterna

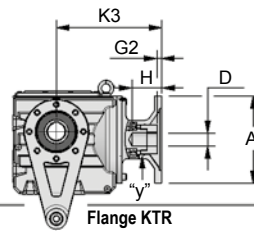

Flange KTR

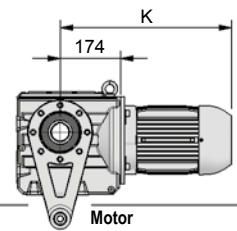

Motor

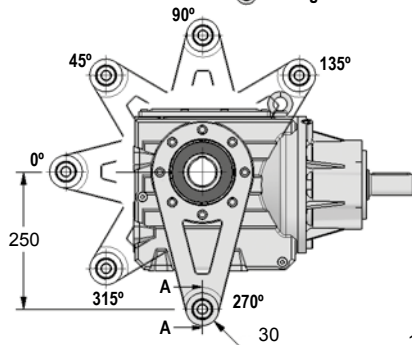

Eixo Vazado com Chaveta

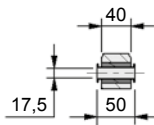

Corte "AA"

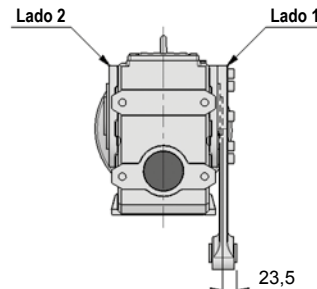

Eixo Vazado com Disco de Contração

Tipos de Saída

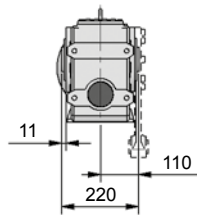

Sugestão de acoplamento no Eixo Vazado

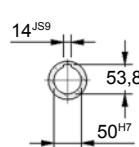

Sugestão de acoplamento no Eixo Vazado com Disco de Contração

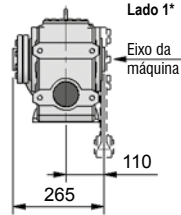

Lado 1\*  
Eixo da máquina

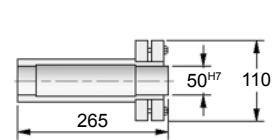
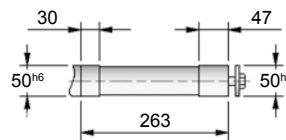
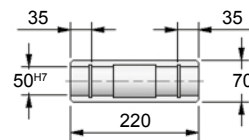
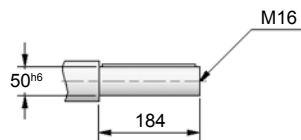

Carcaça	Flange Lanterna / KTR														Motor Elétrico				
	A	B	C	D	E	F	G1	G2	H	K2	K3	S	T	U	K	K4	K5	Q	Q1
80	200	130 <sup>H7</sup>	15	∅19	165	4	10	1	44	438	279	12	21,8	6	455,5	674	515	157	130
90S	200	130 <sup>H7</sup>	15	∅24	165	4	10	1	52	438	279	12	27,3	8	476,5	692	533	177	150
90L	200	130 <sup>H7</sup>	15	∅24	165	4	10	1	52	438	279	12	27,3	8	501,5	717	558	177	150
100	250	180 <sup>H7</sup>	16	∅28	215	5	20	1	63	447	302,5	15	31,3	8	551	763	618,5	198	160
112	250	180 <sup>H7</sup>	16	∅28	215	5	20	1	63	447	302,5	15	31,3	8	566	780	635,5	235	180
132S	300	230 <sup>H7</sup>	17	∅38	265	5	30	1	83	467	355	15	41,3	10	649	839	727	274	207
132M	300	230 <sup>H7</sup>	17	∅38	265	5	30	1	83	467	355	15	41,3	10	687	877	765	274	207
160M	350	250 <sup>H7</sup>	24	∅42	300	6	40	1	112	499	403	19	45,3	12	700	987	891	317	250
160L	350	250 <sup>H7</sup>	24	∅42	300	6	40	1	112	499	403	19	45,3	12	744	1031	935	317	250
180M	350	250 <sup>H7</sup>	24	∅48	300	6	40	1	113	499	403	19	51,8	14	774	1053	957	360	270

\* Lado 2: inverter as posições do disco e entrada do eixo da máquina

# Dimensões

Tamanho **51**

## Fixação por pés - N

Duplex

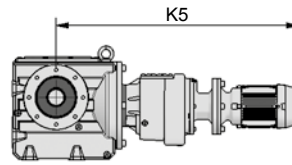
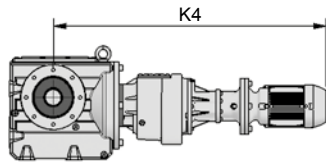
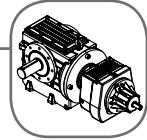

Flange Lanterna com Motor

Flange KTR com Motor

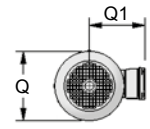
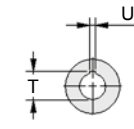
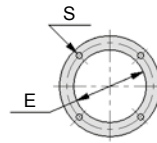
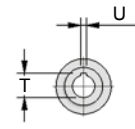
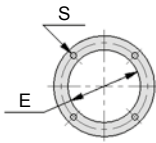
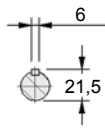

Tipos de Entrada

Eixo de Entrada

Detalhes Flange Lanterna

Detalhe "x"

Detalhes Flange KTR

Detalhe "y"

Frente do Motor

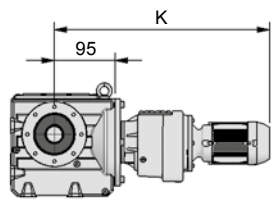
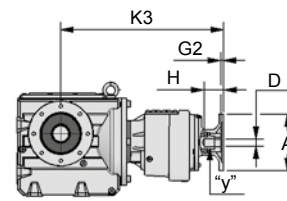
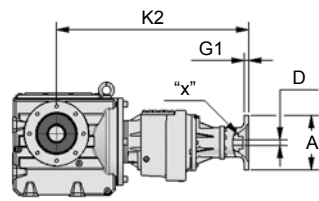
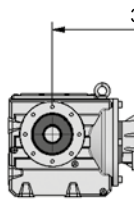

Mancal

Flange Lanterna

Flange KTR

Motor

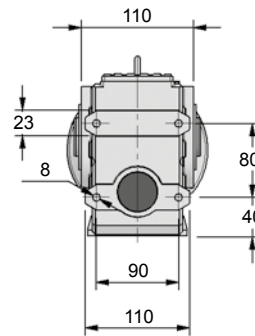
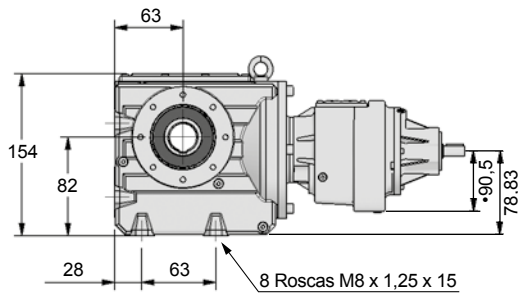

Eixo Integral Simples

Eixo Integral Duplo

Eixo Vazado com Chaveta

Eixo Vazado com Disco de Contração

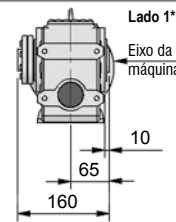
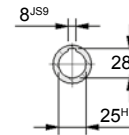
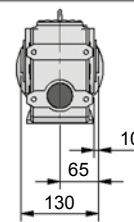
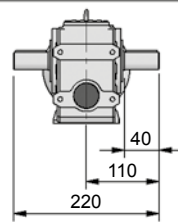
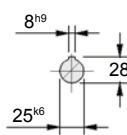
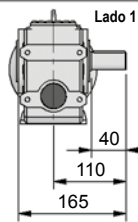

Tipos de Saída

Sugestão de acoplamento no Eixo Vazado

Sugestão de acoplamento no Eixo Vazado com Disco de Contração

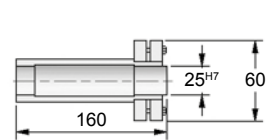
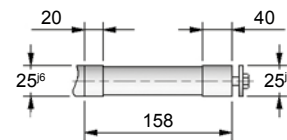
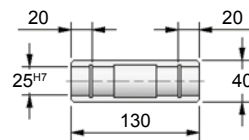
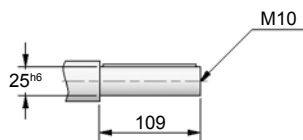

14

Flange Lanterna / KTR

Motor Elétrico

Carcaça	A	B	C	D	E	F	G1	G2	H	K2	K3	S	T	U	K	K4	K5	Q	Q1
63	140	95 <sup>H7</sup>	13	∅11	115	4	0	1	25	430	350,5	10	12,8	4	506	623	474,5	124	113
71	160	110 <sup>H7</sup>	14	∅14	130	4	0,5	1	34	431	350,5	10	16,3	5	538	649	489,5	139	121
80	200	130 <sup>H7</sup>	15	∅19	165	4	10	1	44	448	389	12	21,8	6	565	684	546	157	130
90S	200	130 <sup>H7</sup>	15	∅24	165	4	10	1	52	448	389	12	27,3	8	587	702	566	177	150
90L	200	130 <sup>H7</sup>	15	∅24	165	4	10	1	52	448	389	12	27,3	8	612	727	566	177	150
100	250	180 <sup>H7</sup>	16	∅28	215	5	20	—	—	460	—	15	31,3	8	664	776	—	198	160
112	250	180 <sup>H7</sup>	16	∅28	215	5	20	—	—	460	—	15	31,3	8	—	793	—	235	180

\* Lado 2: inverter as posições do disco e entrada do eixo da máquina

• Verificar interferência com chão / base



# Flange de acoplamento Duplex GGA / G C

Dimensões

Tamanho **51**

Duplex

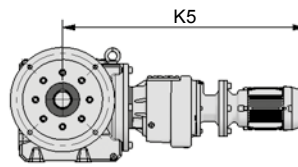
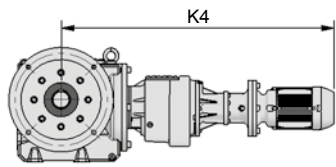

Flange Lanterna com Motor

Flange KTR com Motor

Tipos de Entrada

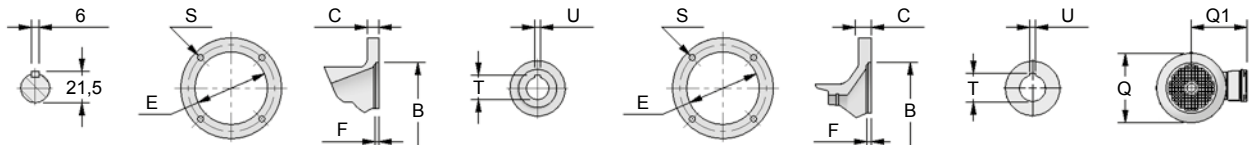

Eixo de Entrada

Detalhes Flange Lanterna

Detalhe "x"

Detalhes Flange KTR

Detalhe "y"

Frente do Motor

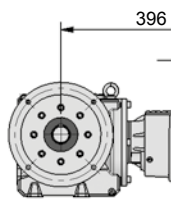

Mancal

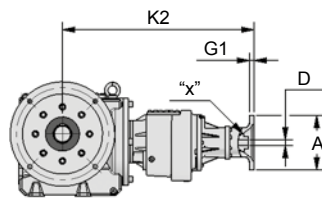

Flange Lanterna

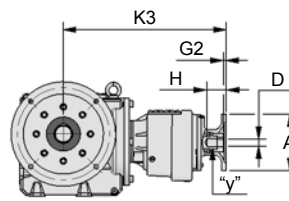

Flange KTR

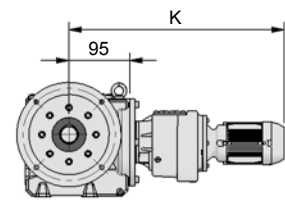

Motor

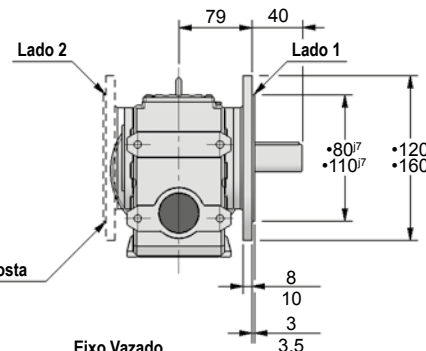
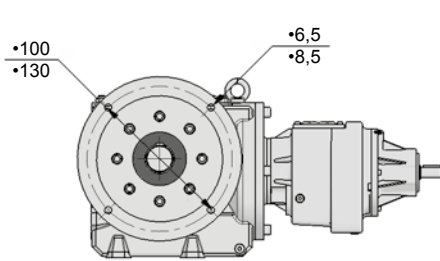

Opção Flange Oposta

Tipos de Saída

Eixo Integral Simples

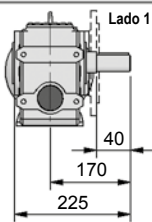

Eixo Integral Duplo

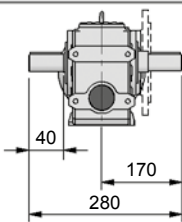

Eixo Vazado com Chaveta

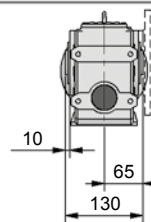

Eixo Vazado com Disco de Contração

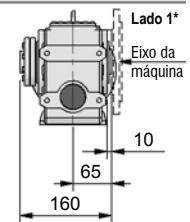

Sugestão de acoplamento no Eixo Vazado

Sugestão de acoplamento no Eixo Vazado com Disco de Contração

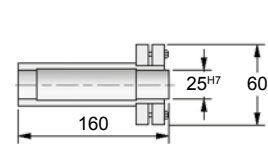
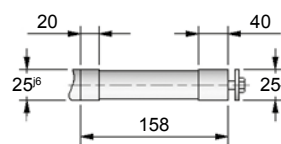
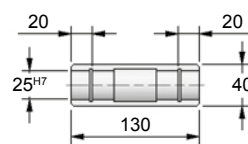
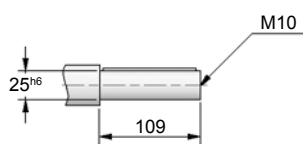

Carcaça	Flange Lanterna / KTR														Motor Elétrico				
	A	B	C	D	E	F	G1	G2	H	K2	K3	S	T	U	K	K4	K5	Q	Q1
63	140	95 <sup>H7</sup>	13	ø11	115	4	0	1	25	430	350,5	10	12,8	4	506	623	474,5	124	113
71	160	110 <sup>H7</sup>	14	ø14	130	4	0,5	1	34	431	350,5	10	16,3	5	538	649	489,5	139	121
80	200	130 <sup>H7</sup>	15	ø19	165	4	10	1	44	448	389	12	21,8	6	565	684	546	157	130
90S	200	130 <sup>H7</sup>	15	ø24	165	4	10	1	52	448	389	12	27,3	8	587	702	566	177	150
90L	200	130 <sup>H7</sup>	15	ø24	165	4	10	1	52	448	389	12	27,3	8	612	727	566	177	150
100	250	180 <sup>H7</sup>	16	ø28	215	5	20	—	—	460	—	15	31,3	8	664	776	—	198	160
112	250	180 <sup>H7</sup>	16	ø28	215	5	20	—	—	460	—	15	31,3	8	—	793	—	235	180

\* Lado 2: inverter as posições do disco e entrada do eixo da máquina - • Disponível em em dois tamanhos de flange: ØA = 120mm (dimensões indicadas no flange superior) - ØC = 160mm (dimensões indicadas no flange inferior)

# Dimensões

Tamanho **51**

## Fixação por braço de torção - B

Duplex

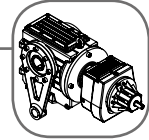

Tipos de Entrada

Tipos de Saída

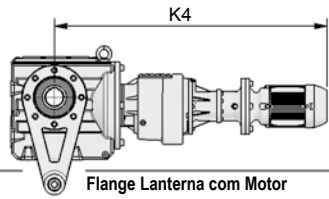

Flange Lanterna com Motor

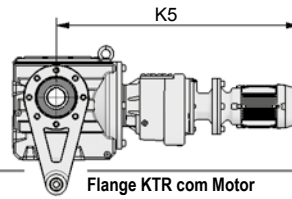

Flange KTR com Motor

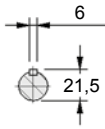

Eixo de Entrada

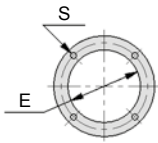

Detalhes Flange Lanterna

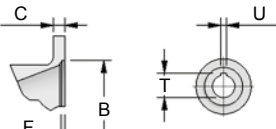

Detalhe "x"

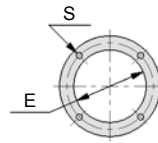

Detalhes Flange KTR

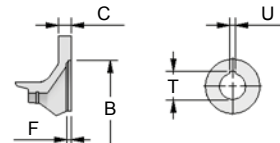

Detalhe "y"

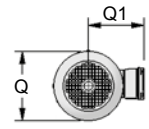

Frente do Motor

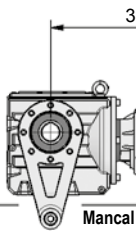

Mancal

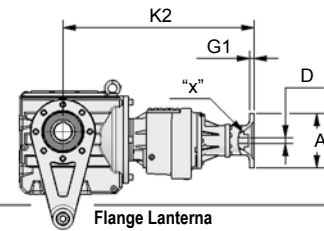

Flange Lanterna

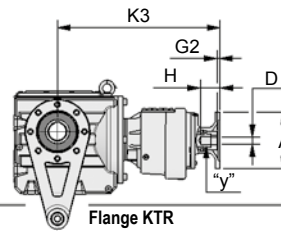

Flange KTR

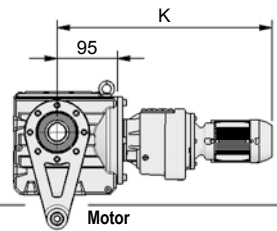

Motor

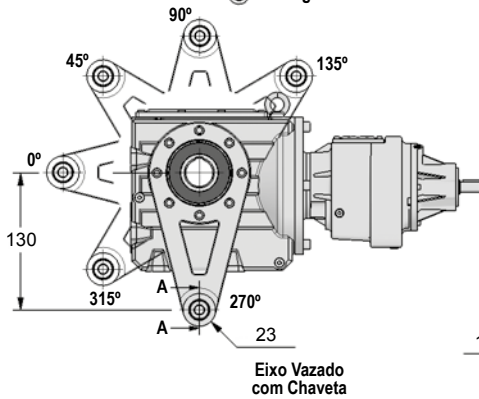

Eixo Vazado com Chaveta

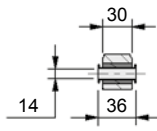

Corte "AA"

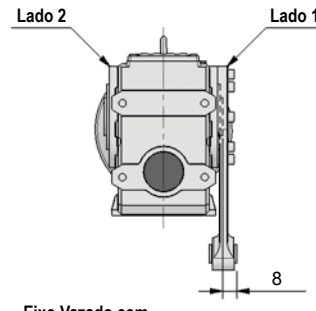

Eixo Vazado com Disco de Contração

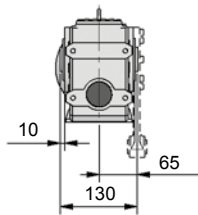

Sugestão de acoplamento no Eixo Vazado

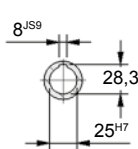

Sugestão de acoplamento no Eixo Vazado com Disco de Contração

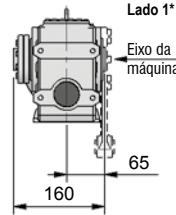

Lado 1\*  
Eixo da máquina

14

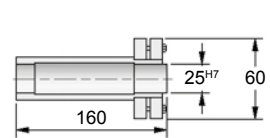
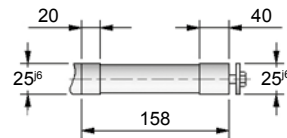
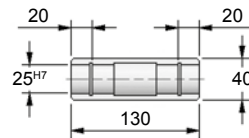
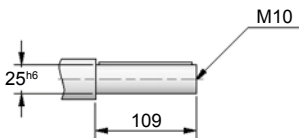

Carcaça	Flange Lanterna / KTR										Motor Elétrico								
	A	B	C	D	E	F	G1	G2	H	K2	K3	S	T	U	K	K4	K5	Q	Q1
63	140	95 <sup>H7</sup>	13	∅11	115	4	0	1	25	430	350,5	10	12,8	4	506	623	474,5	124	113
71	160	110 <sup>H7</sup>	14	∅14	130	4	0,5	1	34	431	350,5	10	16,3	5	538	649	489,5	139	121
80	200	130 <sup>H7</sup>	15	∅19	165	4	10	1	44	448	389	12	21,8	6	565	684	546	157	130
90S	200	130 <sup>H7</sup>	15	∅24	165	4	10	1	52	448	389	12	27,3	8	587	702	566	177	150
90L	200	130 <sup>H7</sup>	15	∅24	165	4	10	1	52	448	389	12	27,3	8	612	727	566	177	150
100	250	180 <sup>H7</sup>	16	∅28	215	5	20	—	—	460	—	15	31,3	8	664	776	—	198	160
112	250	180 <sup>H7</sup>	16	∅28	215	5	20	—	—	460	—	15	31,3	8	—	793	—	235	180

\* Lado 2: inverter as posições do disco e entrada do eixo da máquina



# Fixação por pés - N

## Duplex

### Dimensões

Tamanho **52**

Tipos de Entrada

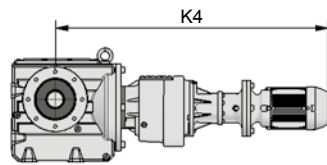

Flange Lanterna com Motor

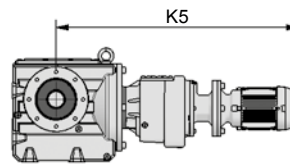

Flange KTR com Motor

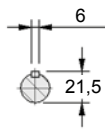

Eixo de Entrada

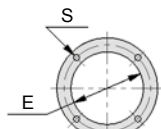

Detalhes Flange Lanterna

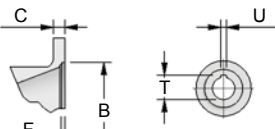

Detalhe "x"

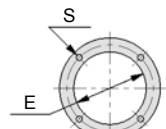

Detalhes Flange KTR

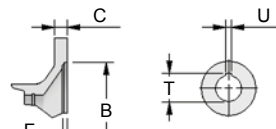

Detalhe "y"

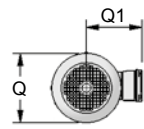

Frente do Motor

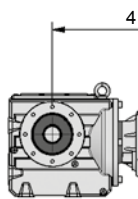

Mancal

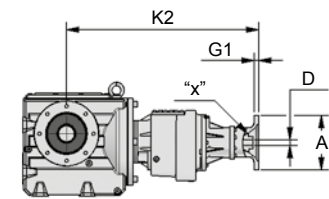

Flange Lanterna

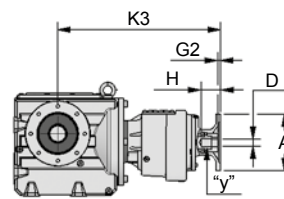

Flange KTR

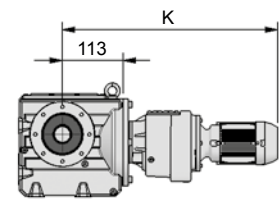

Motor

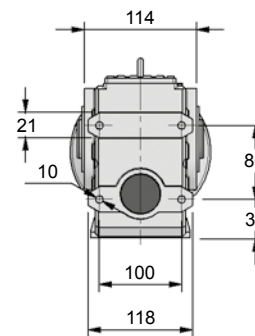
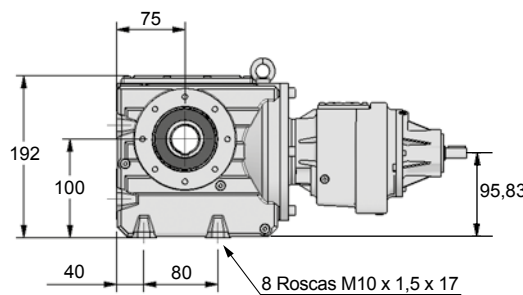

Eixo Integral Simples

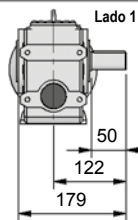

Eixo Integral Duplo

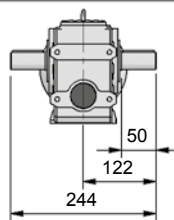

Eixo Vazado com Chaveta

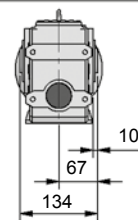

Eixo Vazado com Disco de Contração

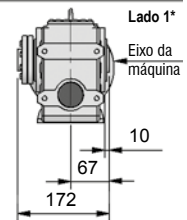

Tipos de Saída

Sugestão de acoplamento no Eixo Vazado

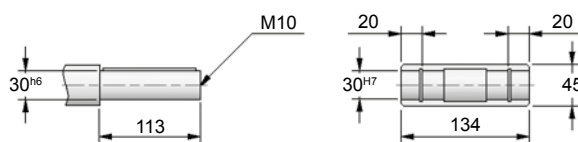

Sugestão de acoplamento no Eixo Vazado com Disco de Contração

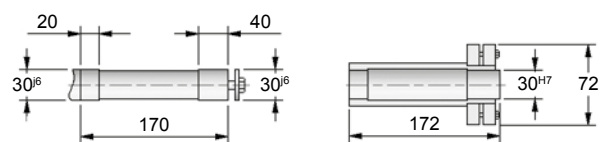

Carcaça	Flange Lanterna / KTR														Motor Elétrico				
	A	B	C	D	E	F	G1	G2	H	K2	K3	S	T	U	K	K4	K5	Q	Q1
63	140	95 <sup>H7</sup>	13	ø11	115	4	0	1	25	448	368,5	10	12,8	4	524	641	561,5	124	113
71	160	110 <sup>H7</sup>	14	ø14	130	4	0,5	1	34	449	368,5	10	16,3	5	556	667	586,5	139	121
80	200	130 <sup>H7</sup>	15	ø19	165	4	10	1	44	466	407	12	21,8	6	583	702	643	157	130
90S	200	130 <sup>H7</sup>	15	ø24	165	4	10	1	52	466	407	12	27,3	8	605	720	661	177	150
90L	200	130 <sup>H7</sup>	15	ø24	165	4	10	1	52	466	407	12	27,3	8	630	745	686	177	150
100	250	180 <sup>H7</sup>	16	ø28	215	5	20	—	—	478	—	15	31,3	8	682	794	—	198	160
112	250	180 <sup>H7</sup>	16	ø28	215	5	20	—	—	478	—	15	31,3	8	—	811	—	235	180

\* Lado 2: inverter as posições do disco e entrada do eixo da máquina

# Dimensões

Tamanho **52**

## Fixação por flange e pés - G. C

Duplex

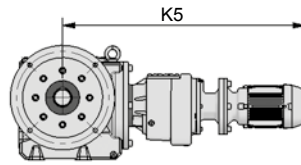
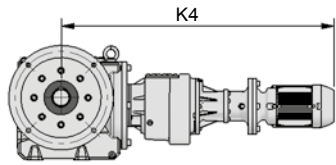

Flange Lanterna com Motor

Flange KTR com Motor

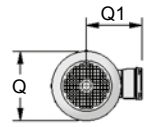
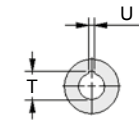
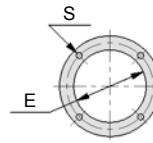
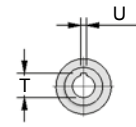
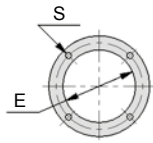
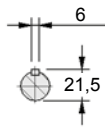

Tipos de Entrada

Eixo de Entrada

Detalhes Flange Lanterna

Detalhe "x"

Detalhes Flange KTR

Detalhe "y"

Frente do Motor

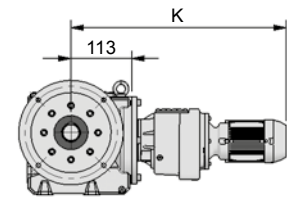
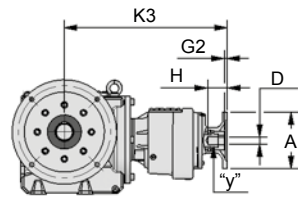
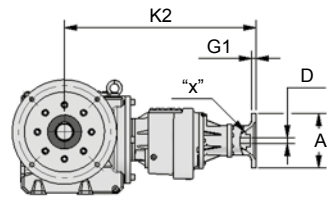
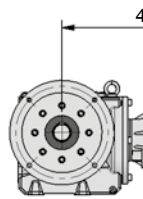

Mancal

Flange Lanterna

Flange KTR

Motor

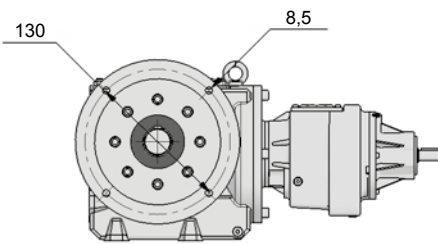

Opção Flange Oposta

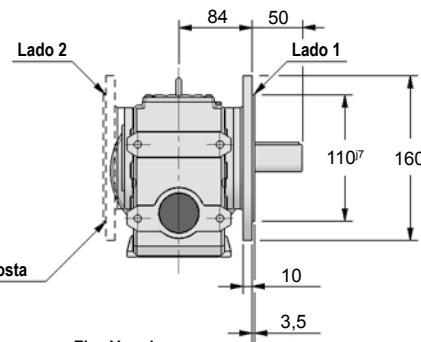

Eixo Integral Simples

Eixo Integral Duplo

Eixo Vazado com Chaveta

Eixo Vazado com Disco de Contração

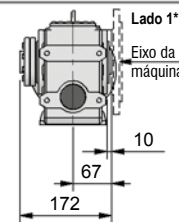
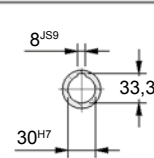
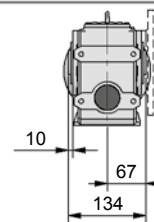
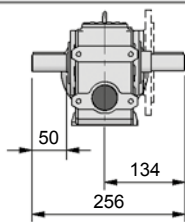
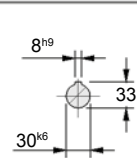
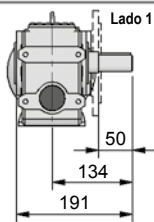

Tipos de Saída

Sugestão de acoplamento no Eixo Vazado

Sugestão de acoplamento no Eixo Vazado com Disco de Contração

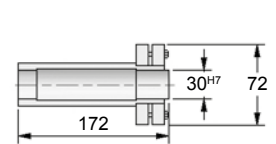
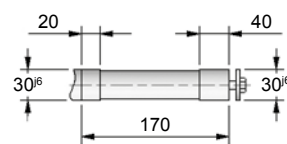
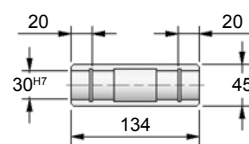
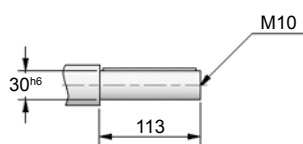

14

Carcaça	Flange Lanterna / KTR										Motor Elétrico								
	A	B	C	D	E	F	G1	G2	H	K2	K3	S	T	U	K	K4	K5	Q	Q1
63	140	95 <sup>H7</sup>	13	ø11	115	4	0	1	25	448	368,5	10	12,8	4	524	641	561,5	124	113
71	160	110 <sup>H7</sup>	14	ø14	130	4	0,5	1	34	449	368,5	10	16,3	5	556	667	586,5	139	121
80	200	130 <sup>H7</sup>	15	ø19	165	4	10	1	44	466	407	12	21,8	6	583	702	643	157	130
90S	200	130 <sup>H7</sup>	15	ø24	165	4	10	1	52	466	407	12	27,3	8	605	720	661	177	150
90L	200	130 <sup>H7</sup>	15	ø24	165	4	10	1	52	466	407	12	27,3	8	630	745	686	177	150
100	250	180 <sup>H7</sup>	16	ø28	215	5	20	—	—	478	—	15	31,3	8	682	794	—	198	160
112	250	180 <sup>H7</sup>	16	ø28	215	5	20	—	—	478	—	15	31,3	8	—	811	—	235	180

\* Lado 2: inverter as posições do disco e entrada do eixo da máquina



# Fixação por braço de torção - B

## Duplex

Dimensões

Tamanho **52**

Tipos de Entrada

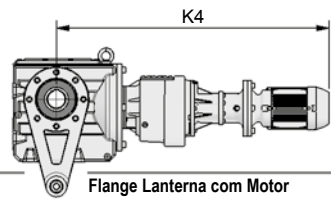

Flange Lanterna com Motor

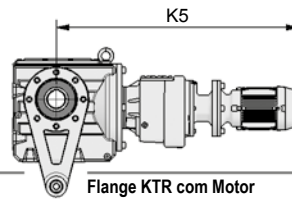

Flange KTR com Motor

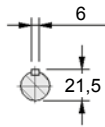

Eixo de Entrada

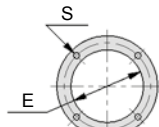

Detalhes Flange Lanterna

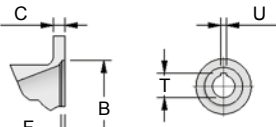

Detalhe "x"

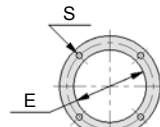

Detalhes Flange KTR

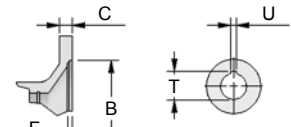

Detalhe "y"

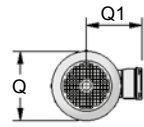

Frente do Motor

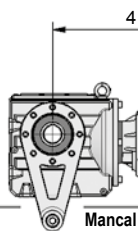

Mancais

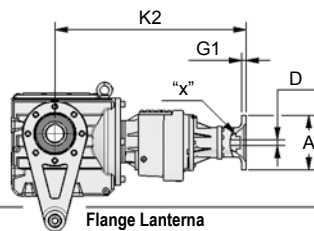

Flange Lanterna

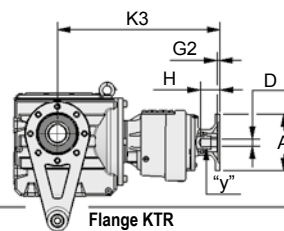

Flange KTR

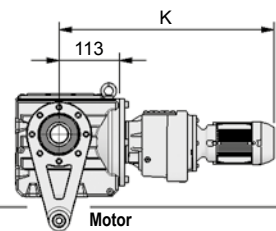

Motor

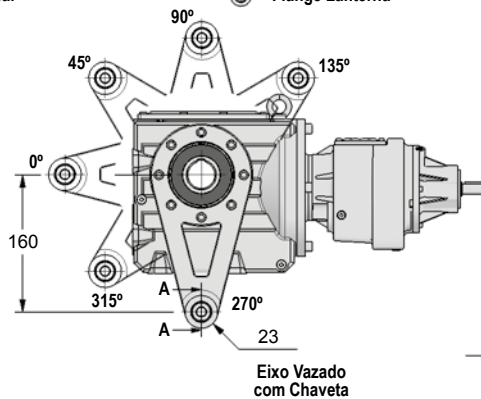

Eixo Vazado com Chaveta

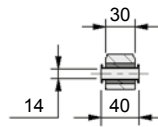

Corte "AA"

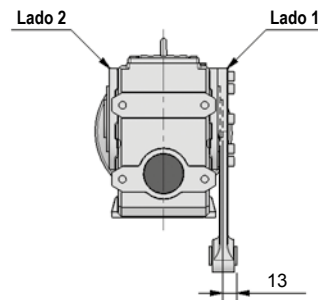

Eixo Vazado com Disco de Contração

Tipos de Saída

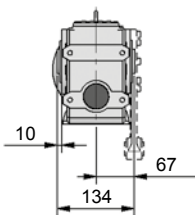

Sugestão de acoplamento no Eixo Vazado

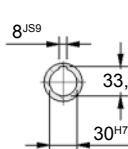

Sugestão de acoplamento no Eixo Vazado com Disco de Contração

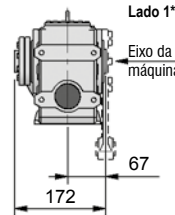

Lado 1\*  
Eixo da máquina

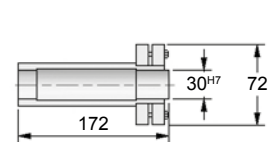
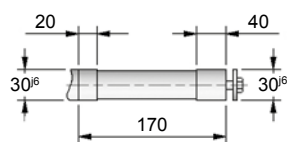
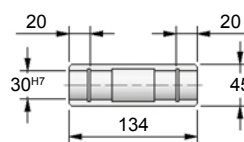
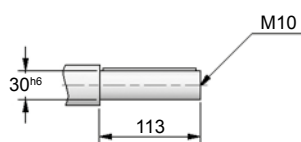

Carcaça	Flange Lanterna / KTR														Motor Elétrico				
	A	B	C	D	E	F	G1	G2	H	K2	K3	S	T	U	K	K4	K5	Q	Q1
63	140	95 <sup>H7</sup>	13	ø11	115	4	0	1	25	448	368,5	10	12,8	4	524	641	561,5	124	113
71	160	110 <sup>H7</sup>	14	ø14	130	4	0,5	1	34	449	368,5	10	16,3	5	556	667	586,5	139	121
80	200	130 <sup>H7</sup>	15	ø19	165	4	10	1	44	466	407	12	21,8	6	583	702	643	157	130
90S	200	130 <sup>H7</sup>	15	ø24	165	4	10	1	52	466	407	12	27,3	8	605	720	661	177	150
90L	200	130 <sup>H7</sup>	15	ø24	165	4	10	1	52	466	407	12	27,3	8	630	745	686	177	150
100	250	180 <sup>H7</sup>	16	ø28	215	5	20	—	—	478	—	15	31,3	8	682	794	—	198	160
112	250	180 <sup>H7</sup>	16	ø28	215	5	20	—	—	478	—	15	31,3	8	—	811	—	235	180

\* Lado 2: inverter as posições do disco e entrada do eixo da máquina



# Dimensões

Tamanho **54**

## Fixação por pés - N

Duplex

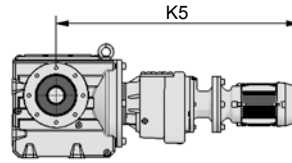
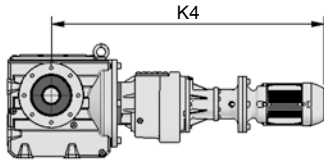
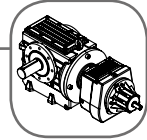

Flange Lanterna com Motor

Flange KTR com Motor

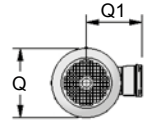
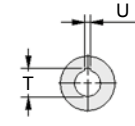
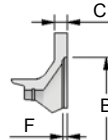
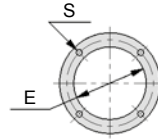
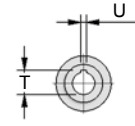
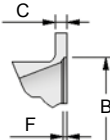
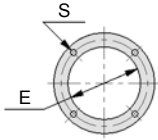
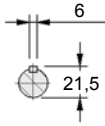

Tipos de Entrada

Eixo de Entrada

Detalhes Flange Lanterna

Detalhe "x"

Detalhes Flange KTR

Detalhe "y"

Frente do Motor

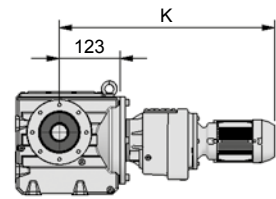
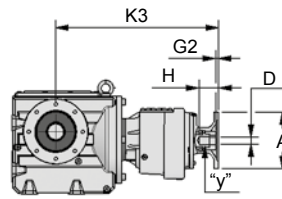
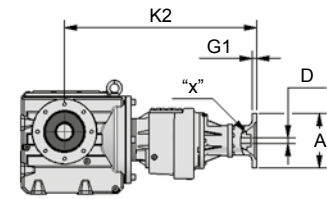
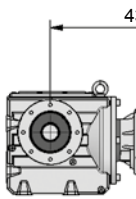

Mancal

Flange Lanterna

Flange KTR

Motor

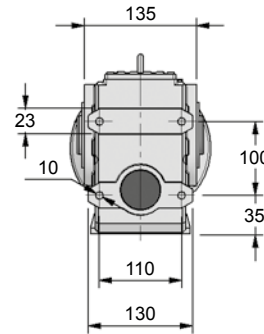
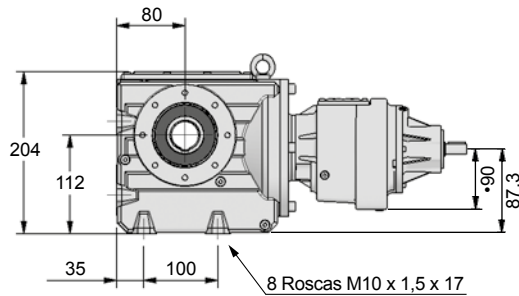

Eixo Integral Simples

Eixo Integral Duplo

Eixo Vazado com Chaveta

Eixo Vazado com Disco de Contração

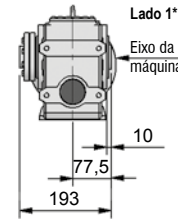
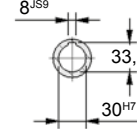
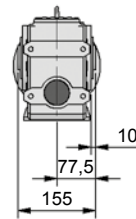
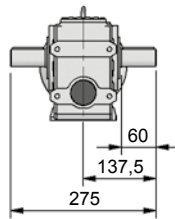
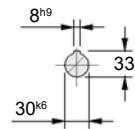
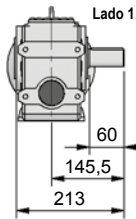

Eixo da máquina

Tipos de Saída

Sugestão de acoplamento no Eixo Vazado

Sugestão de acoplamento no Eixo Vazado com Disco de Contração

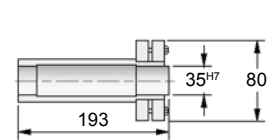
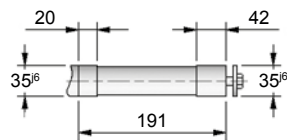
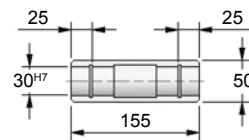
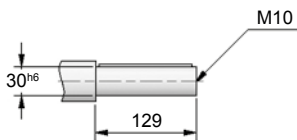

14

Carcaça	Flange Lanterna / KTR										Motor Elétrico								
	A	B	C	D	E	F	G1	G2	H	K2	K3	S	T	U	K	K4	K5	Q	Q1
63	140	95 <sup>H7</sup>	13	∅11	115	4	0	1	25	472	392,5	10	12,8	4	548	665	585,5	124	113
71	160	110 <sup>H7</sup>	14	∅14	130	4	0,5	1	34	473	392,5	10	16,3	5	580	691	610,5	139	121
80	200	130 <sup>H7</sup>	15	∅19	165	4	10	1	44	490	431	12	21,8	6	607	726	667	157	130
90S	200	130 <sup>H7</sup>	15	∅24	165	4	10	1	52	490	431	12	27,3	8	629	744	685	177	150
90L	200	130 <sup>H7</sup>	15	∅24	165	4	10	1	52	490	431	12	27,3	8	654	769	710	177	150
100	250	180 <sup>H7</sup>	16	∅28	215	5	20	—	—	502	—	15	31,3	8	706	818	—	198	160
112	250	180 <sup>H7</sup>	16	∅28	215	5	20	—	—	502	—	15	31,3	8	—	835	—	235	180

\* Lado 2: inverter as posições do disco e entrada do eixo da máquina

• Verificar interferência com chão / base



# Fixação por flange e pés - G D

## Duplex

Dimensões

Tamanho **54**

Tipos de Entrada

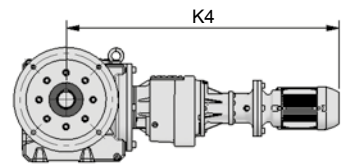

Flange Lanterna com Motor

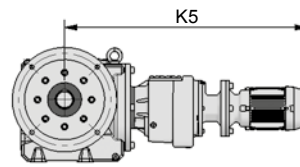

Flange KTR com Motor

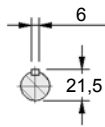

Eixo de Entrada

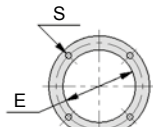

Detalhes Flange Lanterna

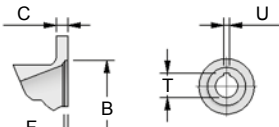

Detalhe "x"

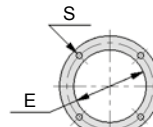

Detalhes Flange KTR

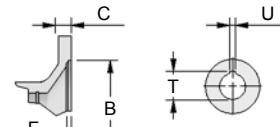

Detalhe "y"

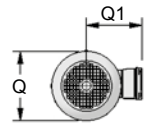

Frente do Motor

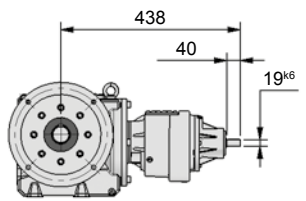

Mancal

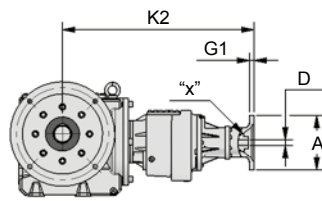

Flange Lanterna

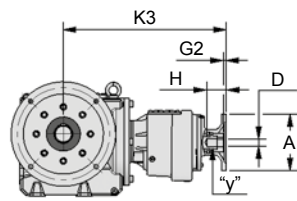

Flange KTR

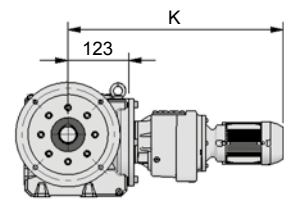

Motor

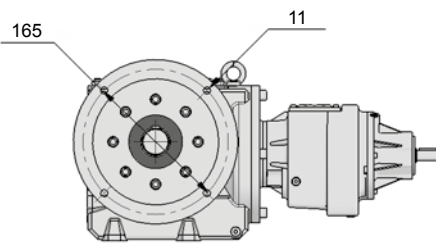

Opção Flange Oposta

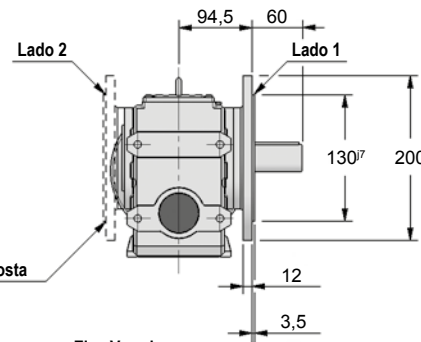

Tipos de Saída

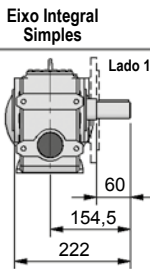

Eixo Integral Simples

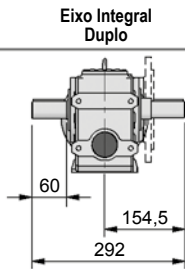
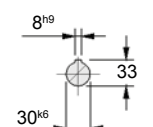

Eixo Integral Duplo

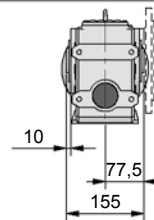

Eixo Vazado com Chaveta

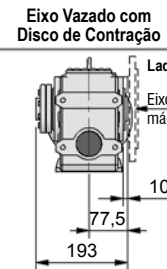
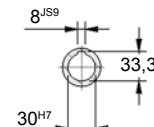

Eixo Vazado com Disco de Contração

Sugestão de acoplamento no Eixo Vazado

Sugestão de acoplamento no Eixo Vazado com Disco de Contração

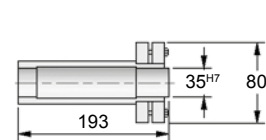
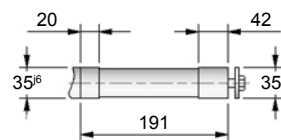
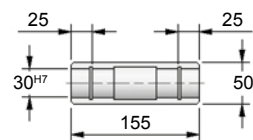
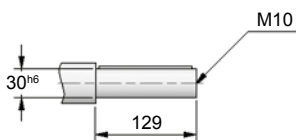

Carcaca	Flange Lanterna / KTR									Motor Elétrico									
	A	B	C	D	E	F	G1	G2	H	K2	K3	S	T	U	K	K4	K5	Q	Q1
63	140	95 <sup>H7</sup>	13	ø11	115	4	0	1	25	472	392,5	10	12,8	4	548	665	585,5	124	113
71	160	110 <sup>H7</sup>	14	ø14	130	4	0,5	1	34	473	392,5	10	16,3	5	580	691	610,5	139	121
80	200	130 <sup>H7</sup>	15	ø19	165	4	10	1	44	490	431	12	21,8	6	607	726	667	157	130
90S	200	130 <sup>H7</sup>	15	ø24	165	4	10	1	52	490	431	12	27,3	8	629	744	685	177	150
90L	200	130 <sup>H7</sup>	15	ø24	165	4	10	1	52	490	431	12	27,3	8	654	769	710	177	150
100	250	180 <sup>H7</sup>	16	ø28	215	5	20	—	—	502	—	15	31,3	8	706	818	—	198	160
112	250	180 <sup>H7</sup>	16	ø28	215	5	20	—	—	502	—	15	31,3	8	—	835	—	235	180

\* Lado 2: inverter as posições do disco e entrada do eixo da máquina

# Dimensões

Tamanho **54**

## Fixação por braço de torção - B

Duplex



Tipos de Entrada

Tipos de Saída

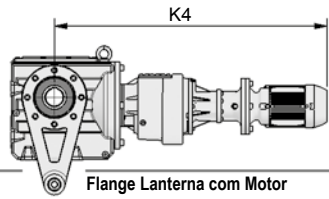

Flange Lanterna com Motor

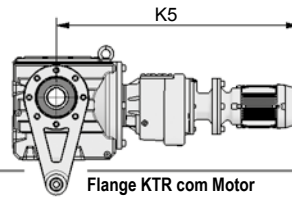

Flange KTR com Motor

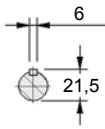

Eixo de Entrada

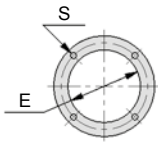

Detalhes Flange Lanterna

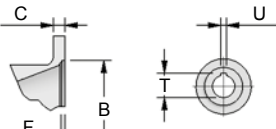

Detalhe "x"

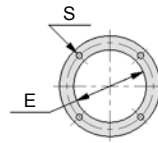

Detalhes Flange KTR

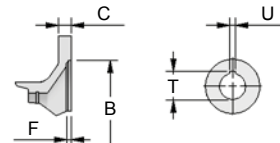

Detalhe "y"

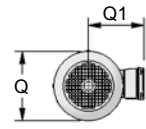

Frente do Motor

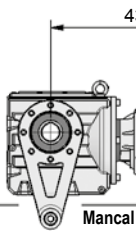

Mancal

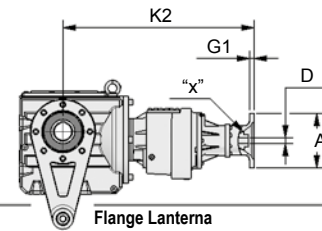

Flange Lanterna

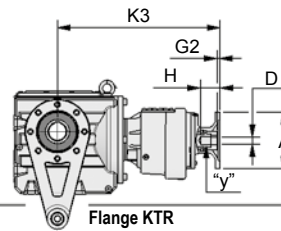

Flange KTR

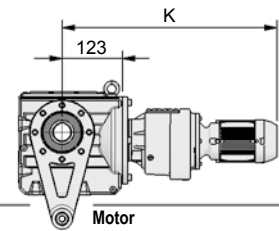

Motor

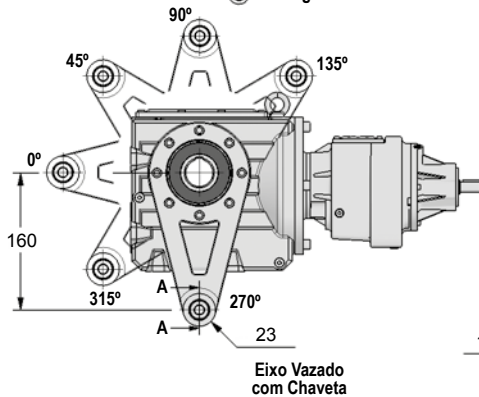

Eixo Vazado com Chaveta

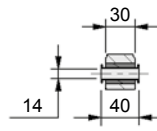

Corte "AA"

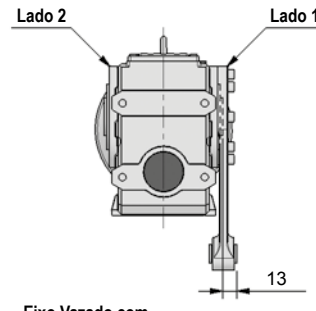

Eixo Vazado com Disco de Contração

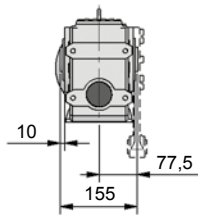

Sugestão de acoplamento no Eixo Vazado

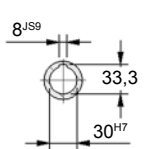

Sugestão de acoplamento no Eixo Vazado com Disco de Contração

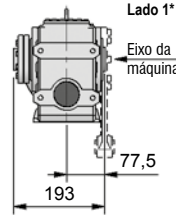

Lado 1\*

Eixo da máquina

14

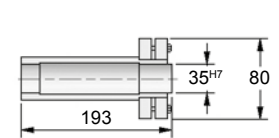
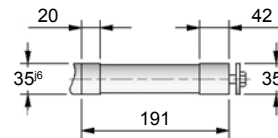
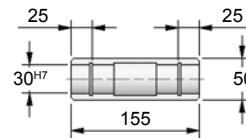
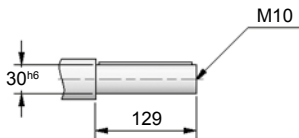

Carcaça	Flange Lanterna / KTR										Motor Elétrico								
	A	B	C	D	E	F	G1	G2	H	K2	K3	S	T	U	K	K4	K5	Q	Q1
63	140	95 <sup>H7</sup>	13	∅11	115	4	0	1	25	472	392,5	10	12,8	4	548	665	585,5	124	113
71	160	110 <sup>H7</sup>	14	∅14	130	4	0,5	1	34	473	392,5	10	16,3	5	580	691	610,5	139	121
80	200	130 <sup>H7</sup>	15	∅19	165	4	10	1	44	490	431	12	21,8	6	607	726	667	157	130
90S	200	130 <sup>H7</sup>	15	∅24	165	4	10	1	52	490	431	12	27,3	8	629	744	685	177	150
90L	200	130 <sup>H7</sup>	15	∅24	165	4	10	1	52	490	431	12	27,3	8	654	769	710	177	150
100	250	180 <sup>H7</sup>	16	∅28	215	5	20	—	—	502	—	15	31,3	8	706	818	—	198	160
112	250	180 <sup>H7</sup>	16	∅28	215	5	20	—	—	502	—	15	31,3	8	—	835	—	235	180

\* Lado 2: inverter as posições do disco e entrada do eixo da máquina



# Fixação por pés - N

## Duplex

### Dimensões

Tamanho **56**

Tipos de Entrada

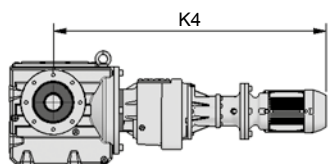

Flange Lanterna com Motor

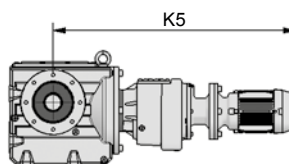

Flange KTR com Motor

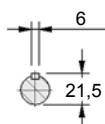

Eixo de Entrada

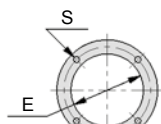

Detalhes Flange Lanterna

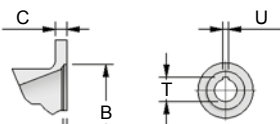

Detalhe "x"

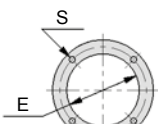

Detalhes Flange KTR

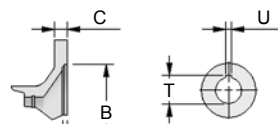

Detalhe "y"

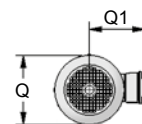

Frente do Motor

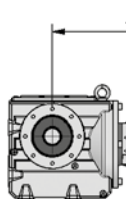

Mancais

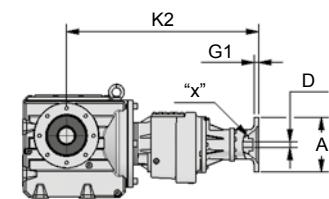

Flange Lanterna

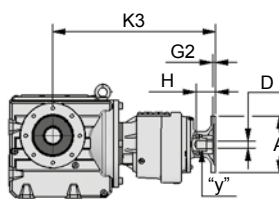

Flange KTR

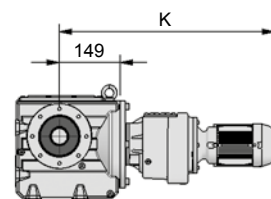

Motor

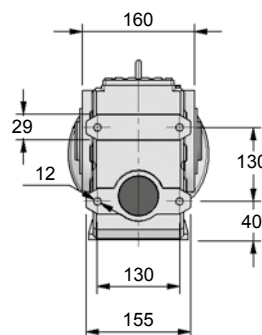
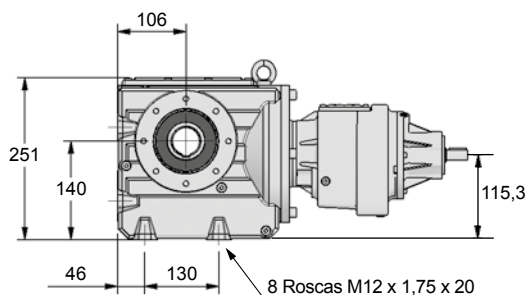

Eixo Integral Simples

Eixo Integral Duplo

Eixo Vazado com Chaveta

Eixo Vazado com Disco de Contração

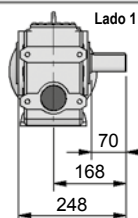

Lado 1

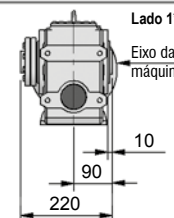
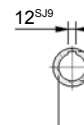
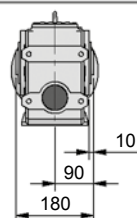
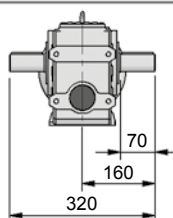
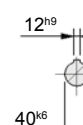

Lado 1\*

Eixo da máquina

Tipos de Saída

Sugestão de acoplamento no Eixo Vazado

Sugestão de acoplamento no Eixo Vazado com Disco de Contração

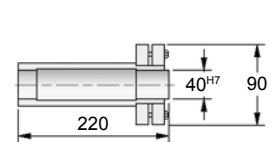
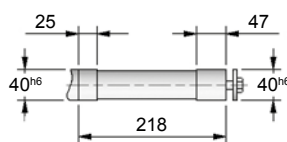
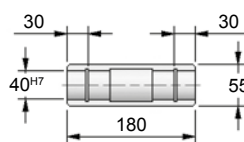
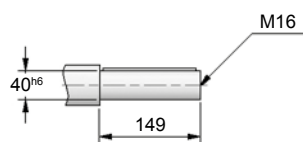

Carcaça	Flange Lanterna / KTR														Motor Elétrico				
	A	B	C	D	E	F	G1	G2	H	K2	K3	S	T	U	K	K4	K5	Q	Q1
63	140	95 <sup>H7</sup>	13	∅11	115	4	0	1	25	498	418,5	10	12,8	4	574	691	611,5	124	113
71	160	110 <sup>H7</sup>	14	∅14	130	4	0,5	1	34	499	418,5	10	16,3	5	606	717	636,5	139	121
80	200	130 <sup>H7</sup>	15	∅19	165	4	10	1	44	516	457	12	21,8	6	633	752	693	157	130
90S	200	130 <sup>H7</sup>	15	∅24	165	4	10	1	52	516	457	12	27,3	8	655	770	711	177	150
90L	200	130 <sup>H7</sup>	15	∅24	165	4	10	1	52	516	457	12	27,3	8	680	795	736	177	150
100	250	180 <sup>H7</sup>	16	∅28	215	5	20	—	—	528	—	15	31,3	8	732	844	—	198	160
112	250	180 <sup>H7</sup>	16	∅28	215	5	20	—	—	528	—	15	31,3	8	—	861	—	235	180

\* Lado 2: inverter as posições do disco e entrada do eixo da máquina

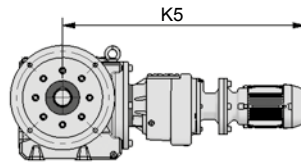
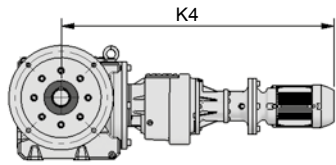

Flange Lanterna com Motor

Flange KTR com Motor

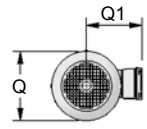
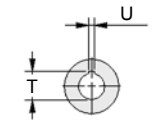
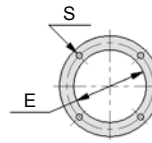
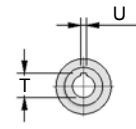
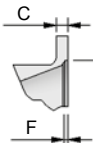
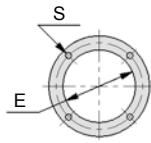
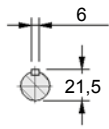

Tipos de Entrada

Eixo de Entrada

Detalhes Flange Lanterna

Detalhe "x"

Detalhes Flange KTR

Detalhe "y"

Frente do Motor

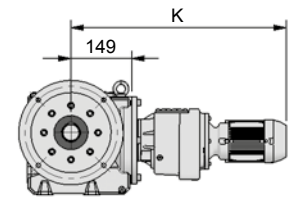
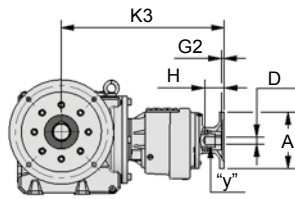
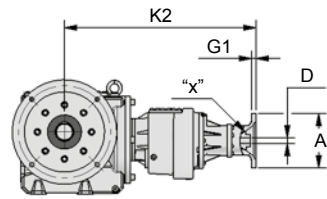
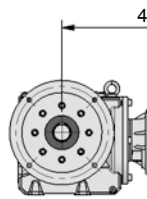

Mancal

Flange Lanterna

Flange KTR

Motor

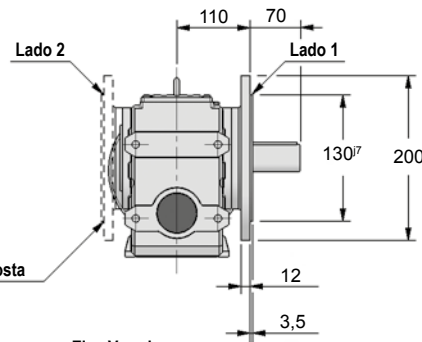
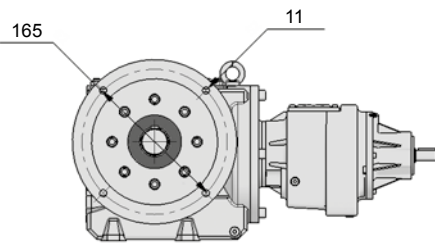

Opção Flange Oposta

Eixo Integral Simples

Eixo Integral Duplo

Eixo Vazado com Chaveta

Eixo Vazado com Disco de Contração

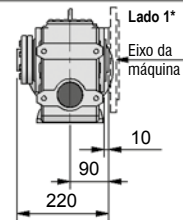
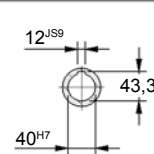
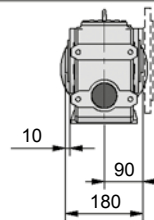
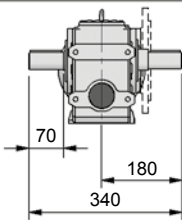
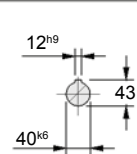
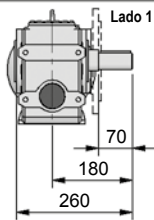

Tipos de Saída

Sugestão de acoplamento no Eixo Vazado

Sugestão de acoplamento no Eixo Vazado com Disco de Contração

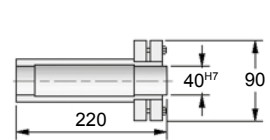
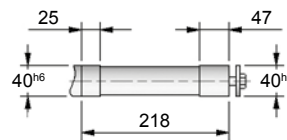
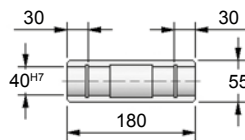
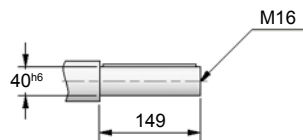

Carcaca	Flange Lanterna / KTR										Motor Elétrico								
	A	B	C	D	E	F	G1	G2	H	K2	K3	S	T	U	K	K4	K5	Q	Q1
63	140	95 <sup>H7</sup>	13	ø11	115	4	0	1	25	498	418,5	10	12,8	4	574	691	611,5	124	113
71	160	110 <sup>H7</sup>	14	ø14	130	4	0,5	1	34	499	418,5	10	16,3	5	606	717	636,5	139	121
80	200	130 <sup>H7</sup>	15	ø19	165	4	10	1	44	516	457	12	21,8	6	633	752	693	157	130
90S	200	130 <sup>H7</sup>	15	ø24	165	4	10	1	52	516	457	12	27,3	8	655	770	711	177	150
90L	200	130 <sup>H7</sup>	15	ø24	165	4	10	1	52	516	457	12	27,3	8	680	795	736	177	150
100	250	180 <sup>H7</sup>	16	ø28	215	5	20	—	—	528	—	15	31,3	8	732	844	—	198	160
112	250	180 <sup>H7</sup>	16	ø28	215	5	20	—	—	528	—	15	31,3	8	—	861	—	235	180

\* Lado 2: inverter as posições do disco e entrada do eixo da máquina



# Fixação por braço de torção - B

## Duplex

Dimensões

Tamanho **56**

Tipos de Entrada

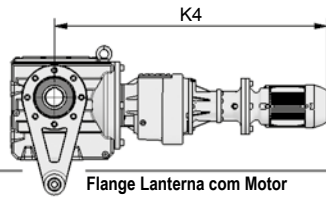

Flange Lanterna com Motor

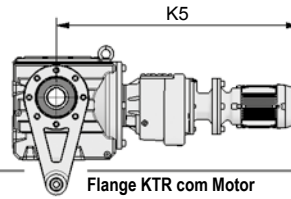

Flange KTR com Motor

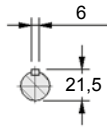

Eixo de Entrada

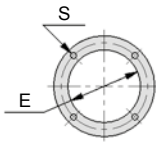

Detalhes Flange Lanterna

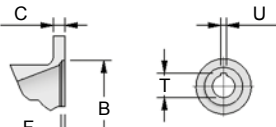

Detalhe "x"

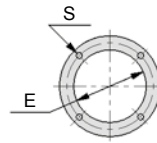

Detalhes Flange KTR

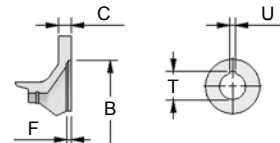

Detalhe "y"

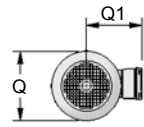

Frente do Motor

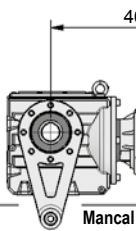

Mancais

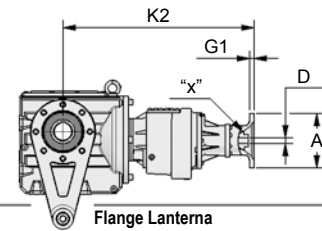

Flange Lanterna

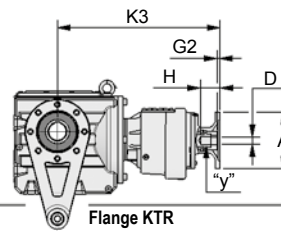

Flange KTR

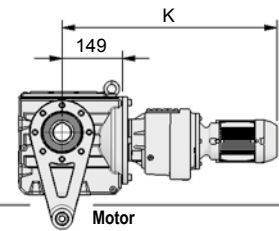

Motor

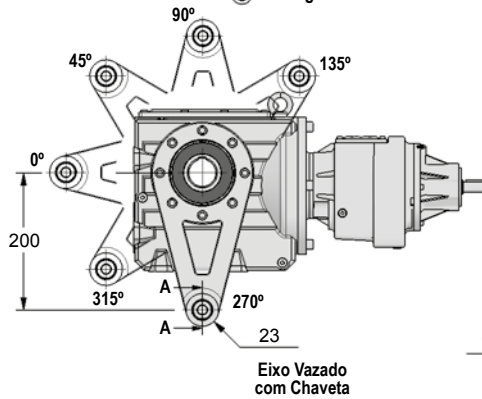

Eixo Vazado com Chaveta

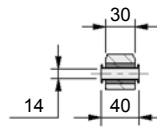

Corte "AA"

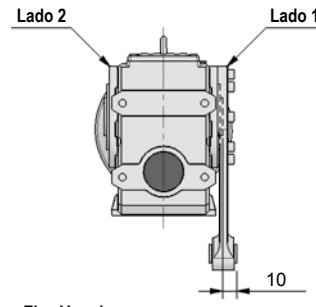

Eixo Vazado com Disco de Contração

Tipos de Saída

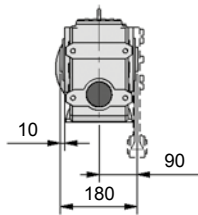

Sugestão de acoplamento no Eixo Vazado

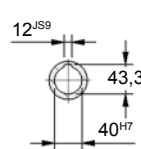

Sugestão de acoplamento no Eixo Vazado com Disco de Contração

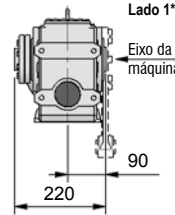

Lado 1\*  
Eixo da máquina

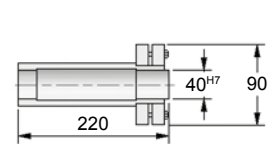
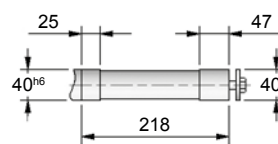
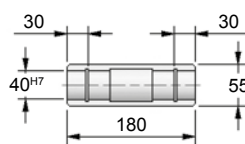
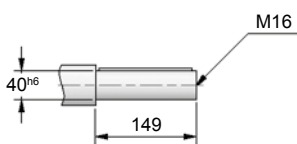

Carcaça	Flange Lanterna / KTR														Motor Elétrico				
	A	B	C	D	E	F	G1	G2	H	K2	K3	S	T	U	K	K4	K5	Q	Q1
63	140	95 <sup>H7</sup>	13	∅11	115	4	0	1	25	498	418,5	10	12,8	4	574	691	611,5	124	113
71	160	110 <sup>H7</sup>	14	∅14	130	4	0,5	1	34	499	418,5	10	16,3	5	606	717	636,5	139	121
80	200	130 <sup>H7</sup>	15	∅19	165	4	10	1	44	516	457	12	21,8	6	633	752	693	157	130
90S	200	130 <sup>H7</sup>	15	∅24	165	4	10	1	52	516	457	12	27,3	8	655	770	711	177	150
90L	200	130 <sup>H7</sup>	15	∅24	165	4	10	1	52	516	457	12	27,3	8	680	795	736	177	150
100	250	180 <sup>H7</sup>	16	∅28	215	5	20	—	—	528	—	15	31,3	8	732	844	—	198	160
112	250	180 <sup>H7</sup>	16	∅28	215	5	20	—	—	528	—	15	31,3	8	—	861	—	235	180

\* Lado 2: inverter as posições do disco e entrada do eixo da máquina

# Dimensões

Tamanho **58**

## Fixação por pés - N

Duplex

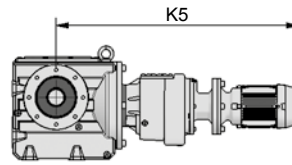
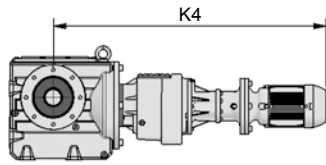
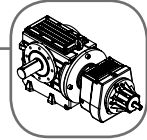

Flange Lanterna com Motor

Flange KTR com Motor

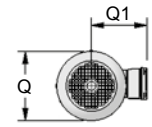
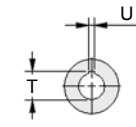
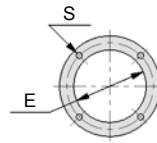
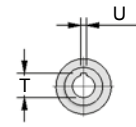
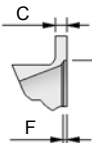
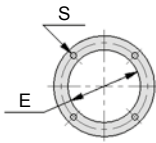
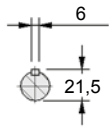

Tipos de Entrada

Eixo de Entrada

Detalhes Flange Lanterna

Detalhe "x"

Detalhes Flange KTR

Detalhe "y"

Frente do Motor

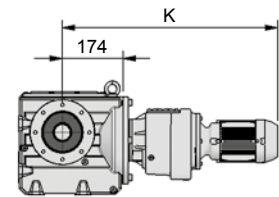
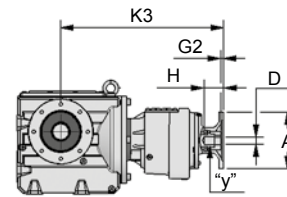
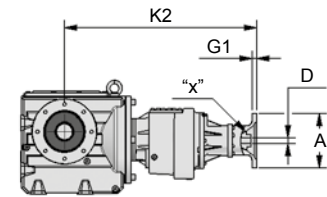
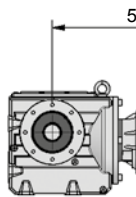

Mancal

Flange Lanterna

Flange KTR

Motor

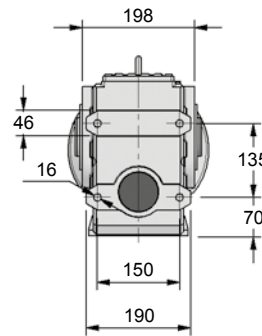
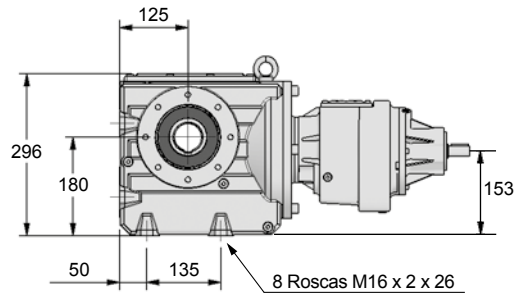

Eixo Integral Simples

Eixo Integral Duplo

Eixo Vazado com Chaveta

Eixo Vazado com Disco de Contração

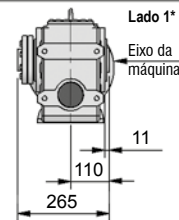
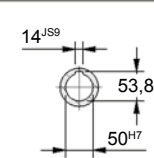
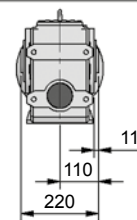
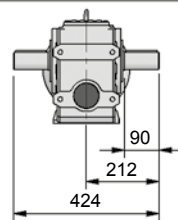
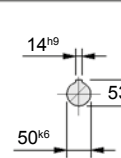
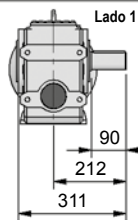

Tipos de Saída

Sugestão de acoplamento no Eixo Vazado

Sugestão de acoplamento no Eixo Vazado com Disco de Contração

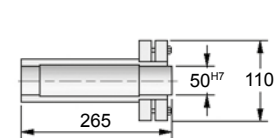
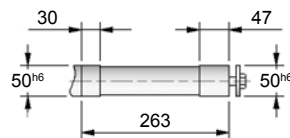
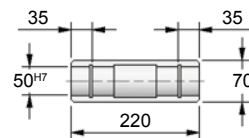
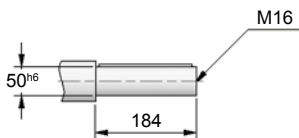

14

Carcaça	Flange Lanterna / KTR													Motor Elétrico					
	A	B	C	D	E	F	G1	G2	H	K2	K3	S	T	U	K	K4	K5	Q	Q1
63	140	95 <sup>H7</sup>	13	∅11	115	4	0	1	25	549	463	10	12,8	4	618,5	742	656	124	113
71	160	110 <sup>H7</sup>	14	∅14	130	4	0,5	1	34	550	463	10	16,3	5	650,5	768	681	139	121
80	200	130 <sup>H7</sup>	15	∅19	165	4	10	1	44	567	501,5	12	21,8	6	677,5	803	737,5	157	130
90S	200	130 <sup>H7</sup>	15	∅24	165	4	10	1	52	567	501,5	12	27,3	8	699,5	821	755,5	177	150
90L	200	130 <sup>H7</sup>	15	∅24	165	4	10	1	52	567	501,5	12	27,3	8	724,5	846	780,5	177	150
100	250	180 <sup>H7</sup>	16	∅28	215	5	20	1	63	579	524	15	31,3	8	774	895	840	198	160
112	250	180 <sup>H7</sup>	16	∅28	215	5	20	1	63	579	524	15	31,3	8	791	912	857	235	180
132S	—	—	—	—	—	—	—	—	—	—	—	—	—	—	877	—	—	274	207
132M	—	—	—	—	—	—	—	—	—	—	—	—	—	—	915	—	—	274	207

\* Lado 2: inverter as posições do disco e entrada do eixo da máquina



# Fixação por flange e pés - G E

## Duplex

Dimensões

Tamanho **58**

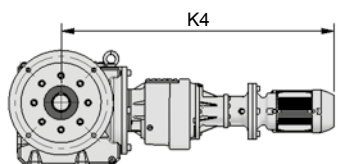

Flange Lanterna com Motor

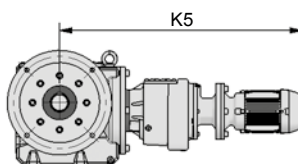

Flange KTR com Motor

Tipos de Entrada

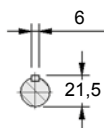

Eixo de Entrada

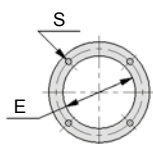

Detalhes Flange Lanterna

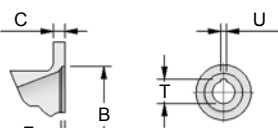

Detalhe "x"

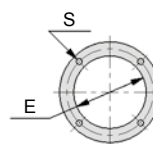

Detalhes Flange KTR

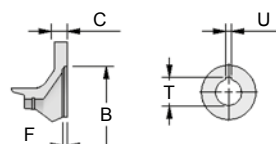

Detalhe "y"

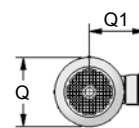

Frente do Motor

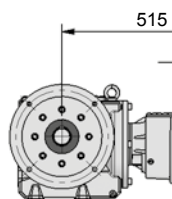

Mancal

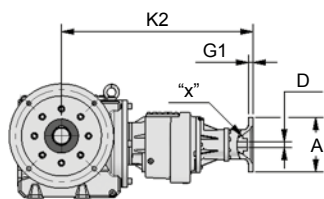

Flange Lanterna

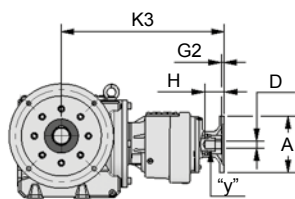

Flange KTR

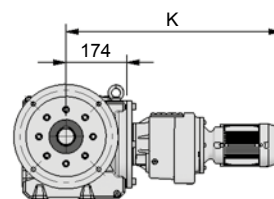

Motor

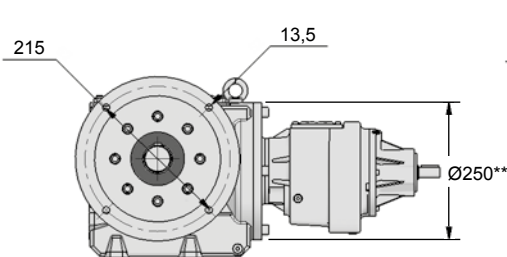

Opção Flange Oposta

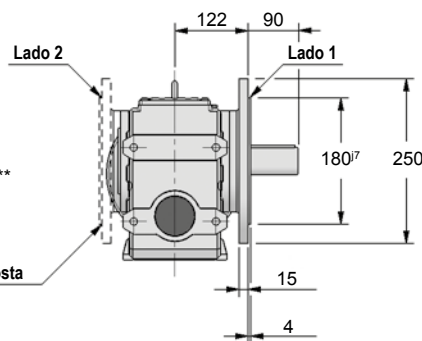

Tipos de Saída

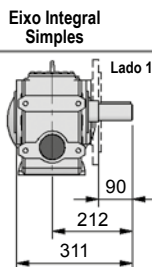

Eixo Integral Simples

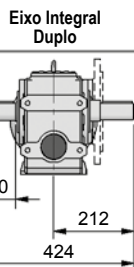
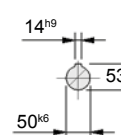

Eixo Integral Duplo

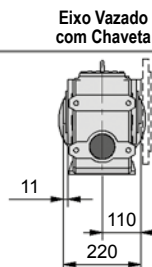

Eixo Vazado com Chaveta

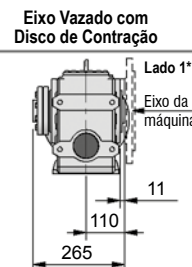
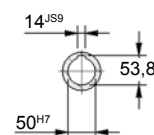

Eixo Vazado com Disco de Contração

Sugestão de acoplamento no Eixo Vazado

Sugestão de acoplamento no Eixo Vazado com Disco de Contração

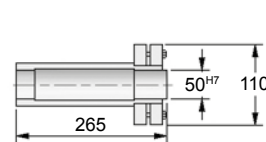
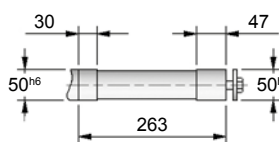
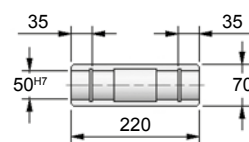
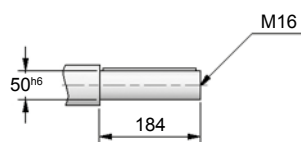

Carcaca	Flange Lanterna / KTR										Motor Elétrico								
	A	B	C	D	E	F	G1	G2	H	K2	K3	S	T	U	K	K4	K5	Q	Q1
63	140	95 <sup>H7</sup>	13	Ø11	115	4	0	1	25	549	463	10	12,8	4	618,5	742	656	124	113
71	160	110 <sup>H7</sup>	14	Ø14	130	4	0,5	1	34	550	463	10	16,3	5	650,5	768	681	139	121
80	200	130 <sup>H7</sup>	15	Ø19	165	4	10	1	44	567	501,5	12	21,8	6	677,5	803	737,5	157	130
90S	200	130 <sup>H7</sup>	15	Ø24	165	4	10	1	52	567	501,5	12	27,3	8	699,5	821	755,5	177	150
90L	200	130 <sup>H7</sup>	15	Ø24	165	4	10	1	52	567	501,5	12	27,3	8	724,5	846	780,5	177	150
100	250	180 <sup>H7</sup>	16	Ø28	215	5	20	1	63	579	524	15	31,3	8	774	895	840	198	160
112	250	180 <sup>H7</sup>	16	Ø28	215	5	20	1	63	579	524	15	31,3	8	791	912	857	235	180
132S	—	—	—	—	—	—	—	—	—	—	—	—	—	—	877	—	—	274	207
132M	—	—	—	—	—	—	—	—	—	—	—	—	—	—	915	—	—	274	207

\* Lado 2: inverter as posições do disco e entrada do eixo da máquina

\*\* Face entrada do redutor tem dimensão Ø250



# Dimensões

Tamanho **58**

## Fixação por braço de torção - B

Duplex



Tipos de Entrada

Tipos de Saída

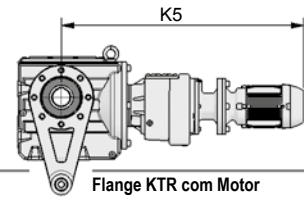
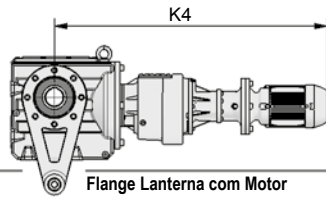

Flange Lanterna com Motor

Flange KTR com Motor

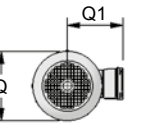
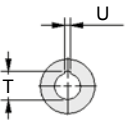
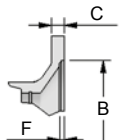
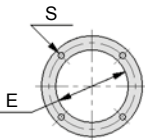
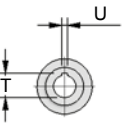
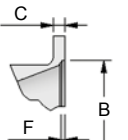
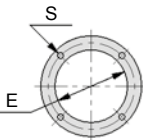
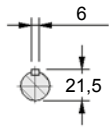

Eixo de Entrada

Detalhes Flange Lanterna

Detalhe "x"

Detalhes Flange KTR

Detalhe "y"

Frente do Motor

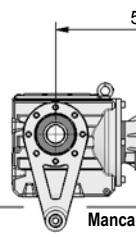

Mancais

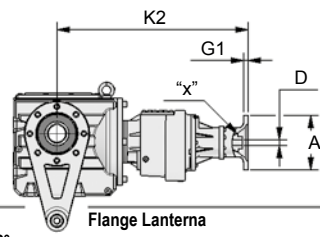

Flange Lanterna

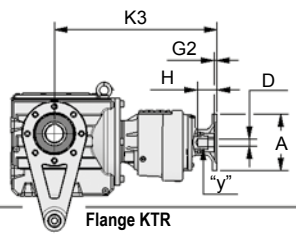

Flange KTR

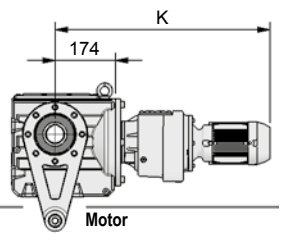

Motor

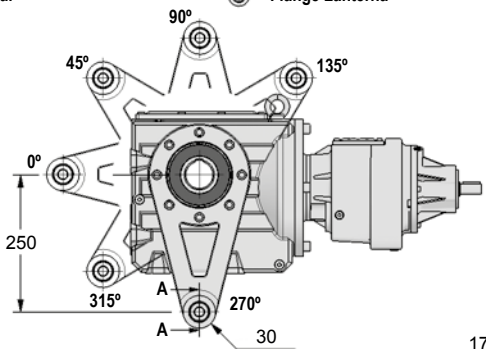

Eixo Vazado com Chaveta

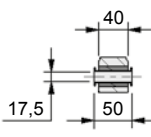

Corte "AA"

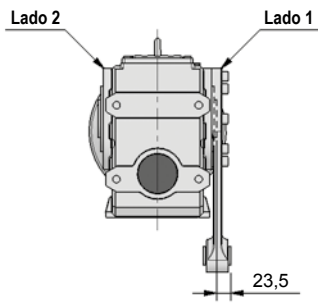

Eixo Vazado com Disco de Contração

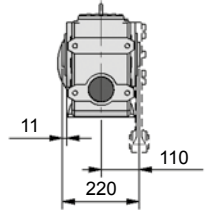

Sugestão de acoplamento no Eixo Vazado

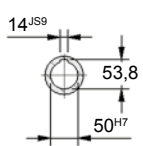

Sugestão de acoplamento no Eixo Vazado com Disco de Contração

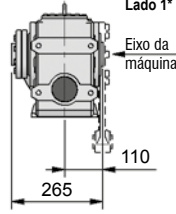

Lado 1\*  
Eixo da máquina

14

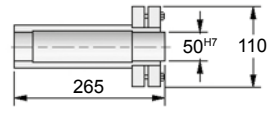
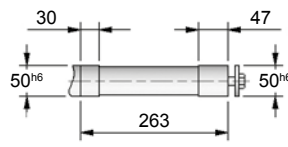
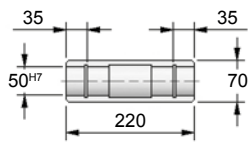
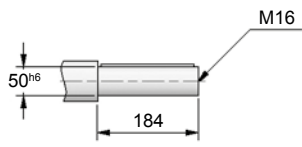

Carcaça	Flange Lanterna / KTR										Motor Elétrico								
	A	B	C	D	E	F	G1	G2	H	K2	K3	S	T	U	K	K4	K5	Q	Q1
63	140	95 <sup>H7</sup>	13	∅11	115	4	0	1	25	549	463	10	12,8	4	618,5	742	656	124	113
71	160	110 <sup>H7</sup>	14	∅14	130	4	0,5	1	34	550	463	10	16,3	5	650,5	768	681	139	121
80	200	130 <sup>H7</sup>	15	∅19	165	4	10	1	44	567	501,5	12	21,8	6	677,5	803	737,5	157	130
90S	200	130 <sup>H7</sup>	15	∅24	165	4	10	1	52	567	501,5	12	27,3	8	699,5	821	755,5	177	150
90L	200	130 <sup>H7</sup>	15	∅24	165	4	10	1	52	567	501,5	12	27,3	8	724,5	846	780,5	177	150
100	250	180 <sup>H7</sup>	16	∅28	215	5	20	1	63	579	524	15	31,3	8	774	895	840	198	160
112	250	180 <sup>H7</sup>	16	∅28	215	5	20	1	63	579	524	15	31,3	8	791	912	857	235	180
132S	—	—	—	—	—	—	—	—	—	—	—	—	—	—	877	—	—	274	207
132M	—	—	—	—	—	—	—	—	—	—	—	—	—	—	915	—	—	274	207

\* Lado 2: inverter as posições do disco e entrada do eixo da máquina



### Motor Weg Tipo 1

Redutor	51	52, 54	56	58
<b>Carcaças</b>				
63				
71				
80				
90				
100				
112				
132				
160				
180				
200				
225				
250				
280				
315				

### Flange Compacta KTR

Redutor	51	52, 54	56	58
<b>Carcaças</b>				
63				
71				
80				
90				
100				
112				
132				
160				
180				
200				
225				
250				
280				

### Flange Lanterna

Redutor	51	52, 54	56	58
<b>Carcaças</b>				
63				
71				
80				
90				
100				
112				
132				
160				
180				
200				
225				

▲ Antes de escolher um redutor com flange, verificar a tabela acima juntamente com os limites mencionados na coluna Carcaças, nas páginas de Características Técnicas (redutores).

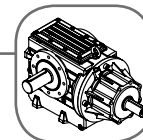

## 1. Controle de recebimento

Recomendamos que, quando do recebimento de nosso Motorreductor Magmax, seja verificado se o produto corresponde ao especificado e seu estado. Caso algum dano tenha sido percebido no produto, solicitamos a imediata comunicação do fato à transportadora e à CESTARI.

## 2. Armazenamento

O local de armazenamento deverá ser seco, isento de gases, fungos, agentes corrosivos e excesso de poeira. Quanto a forma de armazenamento o produto deverá, preferencialmente, ser guardado na posição de trabalho.

## 3. Instalação

As pontas dos eixos e superfícies de fixação são protegidas por uma fina camada de verniz anticorrosivo. Este verniz deverá ser removido, quando da instalação, utilizando-se solventes normais.

**ATENÇÃO:** O solvente não poderá atingir os retentores e jamais use lixa para remoção do verniz.

O Motorreductor deverá ser instalado na posição de trabalho, sobre uma base plana e rígida, permitindo fácil acesso aos dispositivos de lubrificação. Na conexão entre equipamento e Motorreductor é importante um alinhamento preciso.

Quando for acoplada polia, engrenagem ou roda dentada no eixo do Motorreductor, será necessário observar o paralelismo entre os eixos envolvidos, sendo aconselhável que o ponto de aplicação da carga esteja o mais próximo possível da carcaça do reductor.

A montagem do elemento de transmissão deverá ser feita com todo cuidado para evitar danos ao Motorreductor (se necessário utilize o furo de centro rosqueado, na ponta do eixo do reductor, para o travamento axial do elemento de transmissão).

Deverá ser instalado de tal maneira que a carcaça do reductor quando em funcionamento seja pressionada contra a base.

## 4. Operação

Os Motorredutores Magmax são fornecidos prontos para operação. Contudo, antes de iniciar a operação é conveniente verificar o nível do lubrificante. Para evitar vazamento de lubrificante durante o transporte é utilizado um bujão normal, que deverá ser substituído pelo bujão com respiro antes do início de operação.

## 5. Conexão elétrica

A perfeita ligação à rede é fundamental para o bom funcionamento do motor elétrico.

Ao instalar o motor elétrico devem ser observadas as tensões, frequências normais, ambiente (temperatura, ambiente agressivo), altitude e bitola correta dos fios de alimentação.

O esquema de ligação que consta na plaqueta de identificação dos motores deve ser seguido rigorosamente; caso seja necessária a alteração do sentido de rotação, as fases de ligação deverão ser invertidas.

Para maior proteção do usuário, o motor, assim como todo equipamento elétrico, deve possuir uma conexão que o ligue à terra.

## 6. Manutenção

Os Motorredutores Magmax requerem um mínimo de manutenção. Ela é limitada ao controle regular do lubrificante, que deverá ser trocado conforme a Tabela 7 - Tempo de Troca de Óleo, conforme o óleo que está sendo utilizado, sendo que, para condições normais, o óleo fornecido é o Óleo Mineral CLP. Nas primeiras 500 horas de operação, recomenda-se a verificação da qualidade do óleo e, se houver contaminação por partículas, recomenda-se a troca do mesmo e o acompanhamento do reductor.

A temperatura de operação é a temperatura do óleo lubrificante após o período de estabilização da temperatura em plena carga (aproximadamente 3 horas de funcionamento contínuo), sendo que a temperatura externa da carcaça é aproximadamente 15°C menor que a temperatura de operação (temperatura do óleo).

A temperatura de operação para os redutores Cestari é de 18°C (mínima) e 90°C (máxima), em condições normais de funcionamento.

Para trocar o óleo é necessário remover o bujão de dreno e o respiro, devendo o óleo ser drenado ainda quente, para facilitar o escoamento e a limpeza. Recomenda-se lavar o reductor com óleo da mesma marca e tipo, porém com viscosidade menor, e verificação da limpeza de funis e bujões utilizados.

Em caso de condições desfavoráveis de ambiente (alta umidade, agressividade, poeira), recomenda-se reduzir o tempo de troca recomendado, devendo ser consultada a Cestari para orientação específica.

**ATENÇÃO:** Não misture óleos de diferentes tipos ou de diferentes marcas.

Em determinadas execuções existem mancais que são lubrificados a graxa. Tais pontos possuem lubrificação permanente ou então niples de relubrificação.

## 7. Reparos

Os reparos e eventuais desmontagens deverão ser realizados por pessoas qualificadas. Caso isto não seja possível, a unidade deverá ser enviada a CESTARI para execução do serviço.

Quando for necessária a substituição de algum componente, o cliente deverá contactar a CESTARI, fornecendo o número de série do Motorreductor (ver plaqueta de identificação), através do qual poderemos identificar mais rapidamente o componente desejado.

## 8. Lubrificação

A tabela 8 fornece os tipos de lubrificantes recomendados e respectivos fabricantes. A quantidade de lubrificante indicado na plaqueta de identificação e nas tabelas 9 e 10, serve como valor de referência. O volume exato é determinado pelo bujão de nível de óleo.

**Tabela 7** Tempo de troca de óleo

Temperatura de Operação	Óleo Mineral CLP	Óleo Sintético CLP HCHidrocarbons	Óleo Sintético CLP PG Polyglycol
80° C	5000 horas	15000 horas	25000 horas
85° C	3500 horas	10000 horas	18000 horas
90° C	2500 horas	7500 horas	13000 horas
95° C	2000 horas	6000 horas	8500 horas
100° C	—	3800 horas	6000 horas
105° C	—	2500 horas	4000 horas
110° C	—	2000 horas	3000 horas

**Tabela 8** Óleos lubrificantes

Temperatura ambiente	Óleo para redutores			
	-10°C + 40°C	-10°C + 40°C	+40°C +80°C	-40°C +10°C
Grau de Viscosidade ISO VG DIN 51519	ISO VG 460 CLP* DIN 51517-3	ISO VG 460 CLP HC	ISO VG 680 CLP PG	ISO VG 150 CLP HC
<b>Fabricantes</b>				
Castrol	Optigear BM 460	—	—	—
Repsol/YPF	Transmisión EP 460	—	—	—
Kluber	Kluberoil GEM1 - 460N	Klubersynth EG4 - 460	Klubersynth GH6 - 680	Klubersynth EG4 - 150
Mobil	Mobilgear 634	Mobil SHC 634	—	Mobil SHC 629
Petrobrás	Lubrax Industrial EGF460-PS	Lubrax Syntesis Gear O 460	—	—
Shell	Omala 460	Omala 460 HD	Shell Tivela S 680	—
Texaco	Meropa 460	Pinnacle EP 460	Synlube CLP 680	Pinnacle EP 150
<b>Material do Retentor</b>	Nitrílica NBR	NBR / FPM	Viton FPM	Nitrílica NBR

\*Óleo padrão

\*\*Óleo lubrificante para a indústria alimentícia e farmacêutica com requisitos do registro NSF H1 - sob consulta

**Tabela 9** Quantidade de lubrificante em litros dos redutores simples e redutores do 2º estágio dos redutores Duplex

Posição de trabalho	Tamanho do redutor				
	51	52	54	56	58
P1	0,4	0,5	1,0	1,8	3,8
P2	0,8	1,1	2,0	4,0	7,5
P3	0,9	1,5	2,5	5,0	8,8
P4	1,0	1,5	3,0	6,0	11,0
P5	0,8	1,2	2,5	4,5	8,0
P6	0,8	1,2	2,5	4,5	8,0

**Tabela 10** Quantidade de lubrificante em litros dos redutores do 1º estágio dos redutores Duplex

Posição de trabalho	Tamanho do redutor		
	51, 52	54, 56	58
P1	0,3	0,7	0,8
P2	1,0	2,2	2,3
P3	0,6	1,3	1,4
P4	1,0	2,2	2,3
P5	0,5	1,8	1,9
P6	0,7	1,7	1,8

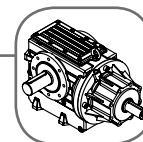

**Tabela 11** Unidades - Grandezas e símbolos

Grandezas Físicas	Símbolo	Unidade SI	Abreviatura da unidade
Tempo	t	Segundo	s
Espaço	s	Metro	m
Velocidade Escalar	v	Metro por segundo	m/s
Aceleração Escalar	$\alpha$	Metro por segundo ao quadrado	m/s <sup>2</sup>
Massa	m	Quilograma	kg
Força	F	Newton	N
Trabalho	$\tau$	Joule	J
Energia	E	Joule	J
Potência	Pot	Watt	W
Impulso	I	Newton x segundo	N . s
Quantidade de movimento	Q	Quilograma x metro por segundo	kg . m/s
Pressão	P	Newton por metro quadrado ou pascal	N/m <sup>2</sup> ou Pa
Densidade	d	Quilograma por metro cúbico	kg/m <sup>3</sup>

**Tabela 12** Conversões de unidades

Multiplique	por	para obter
Atmosfera física (atm) 760 mmHg	101.325	Pa
Bar	100.000	Pa
Cavalo vapor (CV)	0,7355	KW
Dina (dyn)	0,00001	N
Pé (ft)	12	in
Pé (ft)	0,3048	m
Galão (U.S. liquid) (gal)	3,785412	dm <sup>3</sup>
Galão (U.K. liquid) (Imp. gal)	4,546087	dm <sup>3</sup>
Horsepower (HP)	0,7457	KW
Polegada (in)	0,0254	m
Kilograma força Kgf)	9,80665	N
Kilopond (Kp)	9,80665	N
Kilopound (Kip)	4448,222	N
Metros cúbicos (m3)	1.000	litros (l)
Milha, U.S. statute	1609,343	m
Nó (U.S. Knot)	0,514791	m/s
Onça (avoirdupois) (oz)	28,4131	g
Onça (troy) (oz tr)	31,10348	g
Poise (p)	0,1	N , s/m <sup>2</sup>
Pound (avoirdupois) (lb)	0,4536	kg
Pound (avoirdupois) (lb)	16	onca (avdp)
Libra-força por poleg. quadr. (psi)	0,070306	kgf/cm <sup>2</sup>
Libra-força por poleg. quadr. (psi)	6894,757	Pa
RPM	0,1047	radianos / s
Stoke (St)	0,0001	m <sup>2</sup> / s
Tonelada (t)	1.000	kg
Torr	133,322	Pa
Jarda (yd)	3	ft
Jarda (yd)	0,9144	m



Tabela 13 Chavetas plana - Norma DIN 6885 - Folha 1

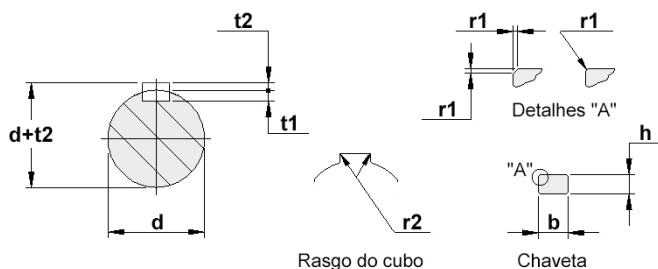

Tolerâncias recomendadas		
Rasgo da chaveta no cubo	Maior pressão	<b>P9</b>
	Menor pressão	<b>JS9</b>
Rasgo de chaveta no eixo	Maior pressão	<b>P9</b>
	Menor pressão	<b>N9</b>
Chaveta plana	Altura	<b>h11</b>
	Largura	<b>h9</b>

Diâmetro do eixo	Largura b	Altura h	Profundidade do rasgo		Tolerância para t1 e t2	Cantos do rasgo do cubo r2		Cantos da chaveta r1	
			Eixo t1	Cubo t2		mínimo	máximo	mínimo	máximo
> 8 a 10	3	3	1,8	1,4	+ 0,1	0,08	0,16	0,16	0,25
> 10 a 12	4	4	2,5	1,8	+ 0,1	0,08	0,16	0,16	0,25
> 12 a 17	5	5	3	2,3	+ 0,1	0,16	0,25	0,25	0,40
> 17 a 22	6	6	3,5	2,8	+ 0,1	0,16	0,25	0,25	0,40
> 22 a 30	8	7	4	3,3	+ 0,2	0,16	0,25	0,25	0,40
> 30 a 38	10	8	5	3,3	+ 0,2	0,25	0,40	0,40	0,60
> 38 a 44	12	8	5	3,3	+ 0,2	0,25	0,40	0,40	0,60
> 44 a 50	14	9	5,5	3,8	+ 0,2	0,25	0,40	0,40	0,60
> 50 a 58	16	10	6	4,3	+ 0,2	0,25	0,40	0,40	0,60
> 58 a 65	18	11	7	4,4	+ 0,2	0,25	0,40	0,40	0,60
> 65 a 75	20	12	7,5	4,9	+ 0,2	0,40	0,60	0,60	0,80
> 75 a 85	22	14	9	5,4	+ 0,2	0,40	0,60	0,60	0,80
> 85 a 95	25	14	9	5,4	+ 0,2	0,40	0,60	0,60	0,80
> 95 a 110	28	16	10	6,4	+ 0,2	0,40	0,60	0,60	0,80
> 110 a 130	32	18	11	7,4	+ 0,2	0,40	0,60	0,60	0,80
> 130 a 150	36	20	12	8,4	+ 0,3	0,70	1,00	1,00	1,20
> 150 a 170	40	22	13	9,4	+ 0,3	0,70	1,00	1,00	1,20
> 170 a 200	45	25	15	10,4	+ 0,3	0,70	1,00	1,00	1,20
> 200 a 230	50	28	17	11,4	+ 0,3	0,70	1,00	1,00	1,20
> 230 a 260	56	32	20	12,4	+ 0,3	1,20	1,60	1,60	2,00
> 260 a 290	63	32	20	12,4	+ 0,3	1,20	1,60	1,60	2,00
> 290 a 330	70	36	22	14,4	+ 0,3	1,20	1,60	1,60	2,00
> 330 a 380	80	40	25	15,4	+ 0,3	2,00	2,50	2,50	3,00
> 380 a 440	90	45	28	17,4	+ 0,3	2,00	2,50	2,50	3,00
> 440 a 500	100	50	31	19,5	+ 0,3	2,00	2,50	2,50	3,00

Tabela 14 Furos de centro 60° com rosca métrica - Norma DIN 332 - Folha 2 - Forma B

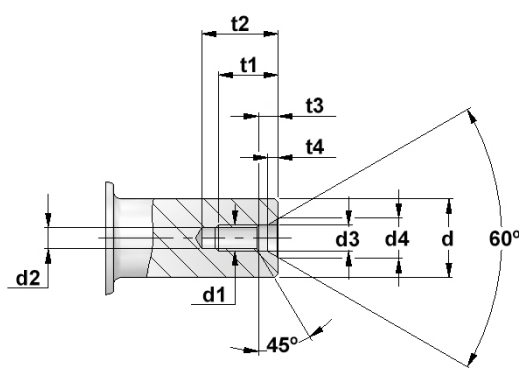

Eixos d	Diâmetro				Profundidade			
	d1	d2	d3	d4	t1	t2	t3	~t4
> 7 a 10	M3	2,5	3,2	5,3	9	13	2,6	1,8
> 10 a 13	M4	3,3	4,3	6,7	10	14	3,2	2,1
> 13 a 16	M5	4,2	5,3	8,1	12,5	17	4	2,4
> 16 a 21	M6	5	6,4	9,6	16	21	5	2,8
> 21 a 24	M8	6,8	8,4	12,2	19	25	6	3,3
> 24 a 30	M10	8,5	10,5	14,9	22	30	7,5	3,8
> 30 a 38	M12	10,2	13	18,1	28	37,5	9,5	4,4
> 38 a 50	M16	14	17	23	36	45	12	5,2
> 50 a 85	M20	17,5	21	28,4	42	53	15	6,4
> 85 a 130	M24	21	25	34,2	50	63	18	8

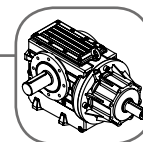

## Furos - Afastamentos em $\mu\text{m}$ (0,001 mm)

Dimensões do furo em mm	Campos de tolerância																									
	F7	F8	G6	G7	H6	H7	H8	H9	J6	J7	JS6	JS7	JS8	JS9	K6	K7	M6	M7	N6	N7	N8	N9	P6	P7	P8	P9
>3 até 6	+22 +10	+28 +10	+12 +4	+16 +4	+8 0	+12 0	+18 0	+30 0	+5 -3	+6 -6	+4 -4	+6 -6	+9 -9	+15 -15	+2 -6	+3 -9	-1 -9	0 -12	-5 -13	-4 -16	-2 -20	0 -30	-9 -17	-8 -20	-12 -30	-12 -42
>6 até 10	+28 +13	+35 +13	+14 +5	+20 +5	+9 0	+15 0	+22 0	+36 0	+5 -4	+8 -7	+4,5 -4,5	+7,5 -7,5	+11 -11	+18 -18	+2 -7	+5 -10	-3 -12	0 -15	-7 -16	-4 -19	-3 -25	0 -36	-12 -21	-9 -24	-15 -37	-15 -51
>10 até 18	+34 +16	+43 +16	+17 +6	+24 +6	+11 0	+18 0	+27 0	+43 0	+6 -5	+10 -8	+5,5 -5,5	+9 -9	+13,5 -13,5	+21,5 -21,5	+2 -9	+6 -12	-4 -15	0 -18	-9 -20	-5 -23	-3 -30	0 -43	-15 -26	-11 -29	-18 -45	-18 -61
>18 até 30	+41 +20	+53 +20	+20 +7	+28 +7	+13 0	+21 0	+33 0	+52 0	+8 -5	+12 -9	+6,5 -6,5	+10,5 -10,5	+16,5 -16,5	+26 -26	+2 -11	+6 -15	-4 -17	0 -21	-11 -24	-7 -28	-3 -36	0 -52	-18 -31	-14 -35	-22 -55	-22 -74
>30 até 50	+50 +25	+64 +25	+25 +9	+34 +9	+16 0	+25 0	+39 0	+62 0	+10 -6	+14 -11	+8 -8	+12,5 -12,5	+19,5 -19,5	+31 -31	+3 -13	+7 -18	-4 -20	0 -25	-12 -28	-8 -33	-3 -42	0 -62	-21 -37	-17 -42	-26 -65	-26 -88
>50 até 80	+60 +30	+76 +30	+29 +10	+40 +10	+19 0	+30 0	+46 0	+74 0	+13 -6	+18 -12	+9,5 -9,5	+15 -15	+23 -23	+37 -37	+4 -15	+9 -21	-5 -24	0 -30	-14 -33	-9 -39	-4 -50	0 -74	-26 -45	-21 -51	-32 -78	-32 -106
>80 até 120	+71 +36	+90 +36	+34 +12	+47 +12	+22 0	+35 0	+54 0	+87 0	+16 -6	+22 -13	+11 -11	+17,5 -17,5	+27 -27	+43,5 -43,5	+4 -18	+10 -25	-6 -28	0 -35	-16 -38	-10 -45	-4 -58	0 -87	-30 -52	-24 -59	-37 -91	
>120 até 180	+83 +43	+106 +43	+39 +14	+54 +14	+25 0	+40 0	+63 0	+100 0	+18 -7	+26 -14	+12,5 -12,5	+20 -20	+31,5 -31,5	+50 -50	+4 -21	+12 -28	-8 -33	0 -40	-20 -45	-12 -52	-4 -67	0 -100	-36 -61	-28 -68	-43 -106	
>180 até 250	+96 +50	+122 +50	+44 +15	+61 +15	+29 0	+46 0	+72 0	+115 0	+22 -7	+30 -16	+14,5 -14,5	+23 -23	+36 -36	+57,5 -57,5	+5 -24	+13 -33	-8 -37	0 -46	-22 -51	-14 -60	-5 -77	0 -115	-41 -70	-33 -79	-50 -122	
>250 até 315	+108 +56	+137 +56	+49 +17	+69 +17	+32 0	+52 0	+81 0	+130 0	+25 -7	+36 -16	+16 -16	+26 -26	+40,5 -40,5	+65 -65	+5 -27	+16 -36	-9 -41	0 -52	-25 -57	-14 -66	-5 -86	0 -130	-47 -79	-36 -88	-56 -137	

## Eixos - Afastamentos em $\mu\text{m}$ (0,001 mm)

Dimensões do eixo em mm	Campos de tolerância																										
	f6	f7	g5	g6	h5	h6	h7	h8	h9	j5	j6	j7	js5	js6	js7	k5	k6	k7	m5	m6	m7	n5	n6	n7	p5	p6	p7
>3 até 6	-10 -18	-10 -22	-4 -9	-4 -12	0 -5	0 -8	0 -12	0 -18	0 -30	+3 -2	+6 -2	+8 -4	+2,5 -2,5	+4 -4	+6 -6	+6 +1	+9 +1	+13 +1	+9 +4	+12 +4	+16 +4	+13 +8	+16 +8	+20 +8	+17 +12	+20 +12	+24 +12
>6 até 10	-13 -22	-13 -28	-5 -11	-5 -14	0 -6	0 -9	0 -15	0 -22	0 -36	+4 -2	+7 -2	+10 -5	+3 -3	+4,5 -4,5	+7,5 -7,5	+7 +1	+10 +1	+16 +1	+12 +6	+15 +6	+21 +6	+16 +10	+19 +10	+25 +10	+21 +10	+24 +15	+30 +21
>10 até 18	-16 -27	-16 -34	-6 -14	-6 -17	0 -8	0 -11	0 -18	0 -27	0 -43	+5 -3	+8 -3	+12 -6	+4 -4	+5,5 -5,5	+9 -9	+9 +1	+12 +1	+19 +1	+15 +7	+18 +7	+25 +7	+20 +12	+23 +12	+30 +12	+26 +18	+29 +18	+36 +18
>18 até 30	-20 -33	-20 -41	-7 -16	-7 -20	0 -9	0 -13	0 -21	0 -33	0 -52	+5 -4	+9 -4	+13 -8	+4,5 -4,5	+6,5 -6,5	+10,5 -10,5	+11 +2	+15 +2	+23 +2	+17 +8	+21 +8	+29 +8	+24 +15	+28 +15	+36 +15	+31 +22	+35 +22	+43 +22
>30 até 50	-25 -41	-25 -50	-9 -20	-9 -25	0 -11	0 -16	0 -25	0 -39	0 -62	+6 -5	+11 -5	+15 -10	+5,5 -5,5	+8 -8	+12,5 -12,5	+13 +2	+18 +2	+27 +2	+20 +9	+25 +9	+34 +9	+28 +17	+33 +17	+42 +17	+37 +26	+42 +26	+51 +26
>50 até 80	-30 -49	-30 -60	-10 -23	-10 -29	0 -13	0 -19	0 -30	0 -46	0 -74	+6 -7	+12 -7	+18 -12	+6,5 -6,5	+9,5 -9,5	+15 -15	+15 +2	+21 +2	+32 +2	+24 +11	+30 +11	+41 +11	+33 +20	+39 +20	+50 +20	+45 +32	+51 +32	+62 +32
>80 até 120	-36 -58	-36 -71	-12 -27	-12 -34	0 -15	0 -22	0 -35	0 -54	0 -87	+6 -9	+13 -9	+20 -15	+7,5 -7,5	+11 -11	+17,5 -17,5	+18 +3	+25 +3	+38 +3	+28 +13	+35 +13	+48 +13	+38 +23	+45 +23	+58 +23	+52 +23	+59 +37	+72 +37
>120 até 180	-43 -68	-43 -83	-14 -32	-14 -39	0 -18	0 -25	0 -40	0 -63	0 -100	+7 -11	+14 -11	+22 -18	+9 -9	+12,5 -12,5	+20 -20	+21 +3	+28 +3	+43 +3	+33 +15	+40 +15	+55 +15	+45 +27	+52 +27	+67 +27	+61 +43	+68 +43	+83 +43
>180 até 250	-50 -79	-50 -96	-15 -35	-15 -44	0 -20	0 -29	0 -46	0 -72	0 -115	+7 -13	+16 -13	+25 -21	+10 -10	+14,5 -14,5	+23 -23	+24 +4	+33 +4	+50 +4	+37 +17	+46 +17	+63 +17	+51 +31	+60 +27	+77 +27	+70 +50	+79 +50	+96 +50
>250 até 315	-56 -88	-56 -108	-17 -40	-17 -49	0 -23	0 -32	0 -52	0 -81	0 -130	+7 -16	+16 -16	+26 -26	+11,5 -11,5	+16 -16	+26 -26	+27 +4	+36 +4	+56 +4	+43 +20	+52 +20	+72 +20	+57 +34	+66 +34	+86 +34	+79 +56	+88 +56	+108 +56



## Peso dos Redutores (kg)

		Motorreduzores											
Simplex	Redutores	63 B	71 C	80 D	90S E	90L F	100 G	112 H	132S J	132M K	160M L	160L M	180 N/P
51	11	19	22	27	32	34	44	—	—	—	—	—	—
52	16	24	27	32	37	39	49	—	—	—	—	—	—
54	21	29	32	37	42	44	54	65	83	93	—	—	—
56	32	40	43	48	53	55	65	76	94	104	146	160	—
58	60	68	71	76	81	83	93	104	122	132	174	188	218
Duplex	Redutores	63 B	71 C	80 D	90S E	90L F	100 G	112 H	132S J	132M K	160M L	160L M	180 N/P
51	25	33	36	41	46	48	58	—	—	—	—	—	—
52	30	38	41	46	51	53	63	—	—	—	—	—	—
54	37	45	48	53	58	60	70	—	—	—	—	—	—
56	48	56	59	64	69	71	81	—	—	—	—	—	—
58	85	93	96	101	106	108	118	129	147	157	—	—	—







FÁBRICA:

Rod. Monte Alto/Vista Alegre, km 3  
Monte Alto | SP | Brasil | 15910-000

VENDAS | (16) 3244-1000 | vendas@wegcestari.com

SERVICE | (16) 3244-1020 | service@wegcestari.com

SAC | (16) 3244-1018 | sac@wegcestari.com

www.wegcestari.com

*Distribuidor - Representante*